

Practice with Praxis

A booklet of practical examples for students using the graphic scientific calculator.

CASIO®

Worldwide Education Web http://world.casio.com/edu_e/



***The Graphic Calculator fx-7400G PLUS,
your powerful math companion.***

This activities book introduces practical examples of problems and exercises that are covered in secondary school and college classes using the CASIO Graphic Scientific Calculator.

As you will see as you go through the problems and exercises, using a graphic scientific calculator does much more than take the work out of calculations. It is also a highly effective educational tool that can help students grasp important concepts and stimulate their imagination. Today, the graphic scientific calculator is highly evaluated as a vital educational tool and is being used extensively in classrooms in Europe, the United States, and other countries around the world.

This manual is a collection of actual problems and exercises, including actual operations. It is intended as the first step for educators who want to start using the graphic scientific calculator in their own classrooms. The material presented here is designed to make problem solving more enjoyable and to cultivate a deeper understanding of mathematics by showing how the graphic scientific calculator can be used to solve a blend of textbook problems and problems faced in everyday life.

Finally, everyone at CASIO would like to express their sincere appreciation to all of the teachers and educators whose cooperation made this activities book possible.

CASIO COMPUTER CO., LTD.

** CONTENTS **

SUBJECT		TITLE	UNIT	AUTHOR	PAGE
Engineering	E-1	Speed and Distance	Equation	Mr. Yuji Kudo	1
	E-2	Function Expressing the Relationship Between Time Taken and Distance Traveled	Quadratic Equation		
	E-3	Automobile Transmission and Engine Speed	Division	Mr. Yuji Kudo	
	E-4	Automobile Gasoline Engine Efficiency	Regression (Linear, Quadratic)	Mr. Mitsugu Tatara	
Engineering Mathematics	EM-1	Water Depth and Flow Velocity	Regression (Exponential)	Mr. Mitsugu Tatara	9
Algebra	A-1	The Calculator 10-key Pad	Addition	Mr. Hideyo Makishita	11
	A-2	Confirmation of the Expression	Quadratic Equation		
	A-3	Straight Line Passing Through Two Points	Linear Regression		
	A-4	Parabola Passing Through Three Points	Quadratic Regression		
Statistics	S-1	Histogram	Standard Deviation	Mr. Hideyo Makishita	13
	S-2	Circle Graph	Ratio		
	S-3	Bar Graph	Graph		
	S-4	Bar Graph and Line Graph	Graph		
Electrical Engineering	EE-1	Relationship Between Voltage, Current, and Power	Regression (Linear, Quadratic)	Mr. Mitsugu Tatara	19
	EE-2	Ohm's Law	Linear Regression	Mr. Takashi Fukazawa	
	EE-3	Small Signal Amplification Factor of a Transistor			
Engineering Chemistry	EC-1	Density of a Liquid	Quadratic Regression	Mr. Mitsugu Tatara	32
	EC-2	Viscosity of a Liquid	Quadratic Regression		
	EC-3	Index of Refraction of a Liquid	Linear Regression		
	EC-4	Solubility Curve	Quadratic Regression		
	EC-5	Specific Gravity of Gas	Division		
Mechanics	M-1	Cam Diagram	Data Collection	Mr. Yuji Kudo	39
	M-2	Stepping Motor Excitation Systems	Optional Device Control		
Algebra Calculation	AC-1	Sum of Products	Multiplication and Addition	Mr. Hiroaki Hashimoto	43
	AC-2	Sum of Products and Mean	Multiplication, Division, and Addition		
	AC-3	Sum	Addition		
	AC-4	Percent	Division		
	AC-5	Calculations Including Trigonometric Functions	Trigonometry		
	AC-6	Permutation and Combination	Permutation and Combination		
Architecture	AR-1	Economy of Materials (Cross-sectional Area)	Quadratic Equation	Mr. Akihiro Shimizu	49
	AR-2	Economy of Materials (Volume)	Cubic Equation		
	AR-3	Concrete Mix Design (Circle Graph)	Ratio		
Quality Control	Q-1	Material Quality Control (Histogram)	Standard Deviation	Mr. Yuji Kudo	55
	Q-2	Component Quality Variation Control (\bar{X} -R Control Chart)	Data Processing		
Others	Z-1	Using a Graphic Calculator (Displaying Calculation Results)			67
	Z-2	Using a Graphic Calculator (Inputting Statistical Data)			
	Z-3	Using a Graphic Calculator (Determining the Slope of a Line)			
	Z-4	Creating Text Materials			

E-1 Speed and Distance

Exercise

Two Cars Traveling at Different Speeds

Two cars, one in Tokyo and one in the Ayuzawa Parking Area (72 kilometers from Tokyo) set off for Nagoya at the same time. Both cars run at constant speeds without stopping, the Tokyo car at 90 km/h and the Ayuzawa car at 60 km/h. Draw a graph that shows at what point the Tokyo car will overtake the Ayuzawa car.

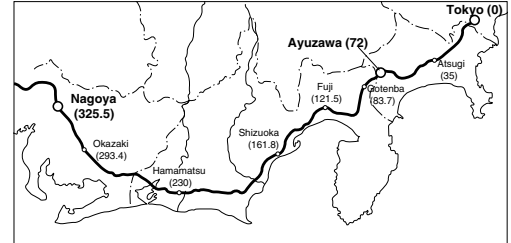

1. Input the formula.

From the Main Menu, enter the GRAPH Mode.

Make sure that Y1: is highlighted and then input the following.

90 $\boxed{X,T}$ \boxed{EXE}

Move the highlighting to Y2: and then input the following.

60 $\boxed{X,T}$ $\boxed{+}$ 72 \boxed{EXE}

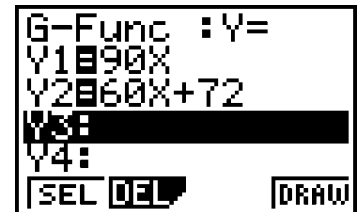

2. Use the View Window to configure graph settings.

Specify the ranges of the X-axis and Y-axis, and their scales.

Input the X-axis range and scale values shown to the right.

\boxed{SHIFT} $\boxed{F3}$ (V-WIN) 0 \boxed{EXE} 5 \boxed{EXE} 1 \boxed{EXE}



Next, input the Y-axis range and scale values shown to the right.

\blacktriangledown 0 \boxed{EXE} 400 \boxed{EXE} 100 \boxed{EXE} \boxed{EXE}

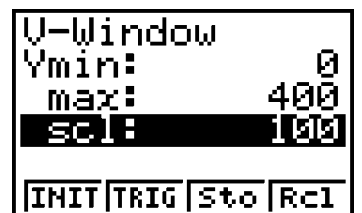

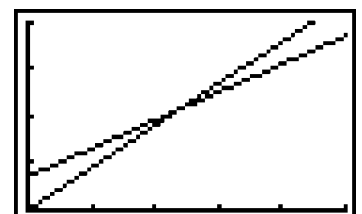

3. Display the graph.

Press $\boxed{F4}$ (DRAW) to draw the graphs.



4. Observe the point where the lines intersect.

- Pressing \boxed{SHIFT} $\boxed{F1}$ (TRCE) displays a pointer on the graph, along with the X and Y values at that point. Use \blacktriangle and \blacktriangledown to select the graph $Y2 = 60X + 72$
- Pressing \blacktriangleleft to move the cursor the point where the graph intersects the Y-axis produces values of $X = 0, Y = 72$. Using the cursor this way is called "tracing."

- Keep pressing  until the cursor is at the point where the two graphs intersect. This produces values that provide an approximate result for the exercise.
- Press **F2** (Zoom) and then **F3** (IN) to enlarge the graph with the cursor location as the center. Repeat this step a number of times and use **SHIFT F1** (TRCE)  to move the cursor closer to the intersect point and produce a more accurate value.

Summary

If, when you use other formulas for the above exercise, the graphs do not intersect, try increasing the X-axis and Y-axis ranges. Check the results on the display and make further adjustments, if required.

E-2 Function Expressing the Relationship Between Time Taken and Distance Traveled

JIKKYO SHUPPAN CO., LTD.: SHIN KOGYO SURU
(NEW EDITION)

Exercise

Function Expressing the Relationship Between Time and Distance Traveled

The nearby table is being configured for $s = f(t)[m]$, when it is assumed that distance covered s [m] is a function of time taken t [sec]. Complete the table and graph the expression $f(t)$.

Time t		Distance s	
[min]	[sec]	[km]	[m]
0.5		0.125	
1.0		0.500	
1.5		1.125	
2.0		2.000	
2.5		3.125	
3.0		4.500	

1. Input the table.

From the Main Menu, enter the STAT Mode.

After making sure the first line of List 1 is highlighted, input the following.

30 [EXE] **60** [EXE] **90** [EXE] ... **180** [EXE]

After making sure the first line of List 2 is highlighted, input the following.

125 [EXE] **500** [EXE] **1125** [EXE] ... **4500** [EXE]

	List 1	List 2
5	150	3125
6	180	4500
7		

[DEL] [DEL] [INS]

2. Configure graph settings.

Press **F1** (GRPH) [▶] **F4** (SET) and check the graph settings.

Use ▲ and ▼ to move the highlighting to G-Type.

Press **F2** (xy) so the screen appears as shown to the right.

StatGraph1	
G-Type	:xyLin
XList	:List1
YList	:List2
Freq	:1
Scat	:XY
Pie	:Pie
Stck	:Stck

3. Draw the graph.

Press **QUIT** **F1** (GRPH) **F1** (GPH1) to display a graph in which plotted points are linked.

4. Configure graph 2.

Press **QUIT** and then **F1** (GRPH) [▶] **F4** (SET), and check the graph settings.

Move the highlighting to G-Type and then press **F1** (Scat).

The display should change as shown to the right.

StatGraph1	
G-Type	:Scat
XList	:List1
YList	:List2
Freq	:1
Scat	:XY
Pie	:Pie
Stck	:Stck

5. Draw graph 2.

Press **QUIT** **F1** (GRPH) **F1** (GPH1).

The graph that appears is a scatter diagram.

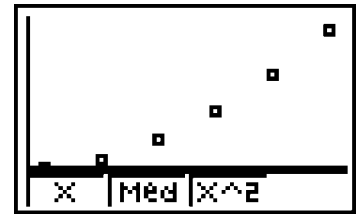
**6. Perform quadratic regression.**

Press **F3** (X^2) to perform quadratic regression and obtain the function.

Press **F4** (DRAW) to draw the graph, which is overlaid onto the scatter diagram as shown to the right.

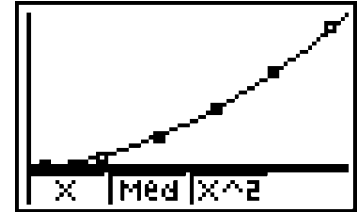
**7. Check the function.**

Check **F3** (X^2) again to display the parameter screen shown to the right. This provides us with the following function.

$$s = f(t) = 0.13888 t^2 = \frac{1}{7.2} t^2$$

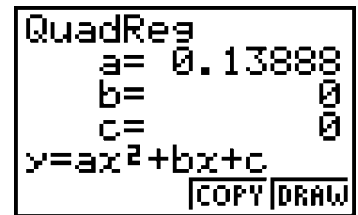
**Summary**

In this exercise, the quadratic regression overlaid nicely onto the scatter diagram. When the overlay is not as successful the one used here, try returning to the graph screen and using linear regression, logarithmic regression, or some other type of regression.

E-3 Automobile Transmission and Engine Speed

JIKKYO SHUPPAN CO., LTD.: SHIN KOGYO SURI
(NEW EDITION)

Exercise

Relationship between an Automobile's Transmission and Engine Speed

Create a program that determines the rotation speed n_p [rpm] of an automobile's propeller shaft in each gear for an engine running at $n_e = 2000$ rpm.

Gear Shift Position	1st	2nd	3rd	4th	5th	R
Gear Ratio	3.6	2.1	1.4	1.0	0.8	4.2

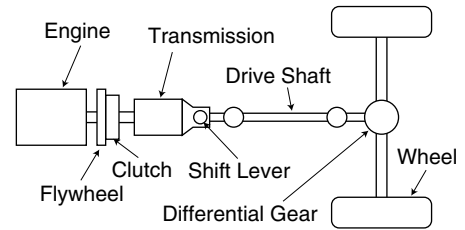

1. Program

From the Main Menu, enter the PRGM Mode.

Input "NP" as the program name.

F3 (NEW) **8** (N) **4** (P) **EXE**

Line 1 **SHIFT** **VAR**S (PRGM) **▶** **F1** (?) **→** **ALPHA** **X,T** (A) **EXE**

Line 2 2000 **÷** **ALPHA** **X,T** (A) **→** **ALPHA** **log** (B) **EXE**

Line 3 **QUIT** **▶** **F2** (") **SHIFT** **ALPHA** (**A**-LOCK) **8** (N) **4** (P) **SHIFT** **•** (=) **F2** (")

SHIFT **VAR**S (PRGM) **▶** **▶** **F3** (:) **ALPHA** **log** (B) **EXE** **QUIT** **QUIT**

2. Program Description

```

= NP =
?→A↵
2000÷A→B↵
"NP=":B↵
TOP |BTM |MENU
    
```

- Program name (NP)
- Assigns input gear ratio to variable A.
- Assigns calculated result ($2000 \div \text{Variable A}$) to variable B.
- Displays "NP=" followed by the value assigned to variable B.
- * "↵" marks indicate return (enter) symbols.

3. Program Execution

From the Main Menu, enter the PRGM Mode.

Use **▲** and **▼** to select "NP," and then press **EXE**.

Input a gear ratio and press **EXE**. This calculates and displays the engine speed.

4. Practical Example

The screen to the right shows an example of what appears when a gear ratio of 3.6 is input.

```
?  
3.6  
NP=  
555.555556
```

Summary

The program can be made even more useful by modifying it to accept input of engine speed as well. You can also control the number of decimal places and significant digits.

E-4 Automobile Gasoline Engine Efficiency

Exercise

The following is a table of fuel efficiency measurement results for an automobile gasoline engine. Draw a graph of the rate of change in the data.

■ Measurement Results

Sample	Engine Speed n [rpm]	Torque T0 [kgf·m]	Output NO [PS]	Fuel Efficiency f0 [gf/PSH]
1	1040	7.05	10.24	327.66
2	1505	7.51	15.79	279.61
3	2000	7.78	21.74	257.26
4	2560	7.88	28.17	240.67
5	3020	7.58	32.00	233.02
6	3500	7.27	35.53	233.15
7	4010	6.61	37.02	241.72

■ Graphic Calculator Operation

1. Data Input

From the Main Menu, enter the STAT Mode.

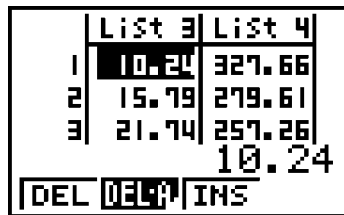

Input the data into List 1 to List 4.

List 1: Engine speed

List 2: Torque

List 3: Output

List 4: Fuel Efficiency

2. Engine Speed – Torque Graph: Graph 1

F1 (GRPH)



F4 (SET)

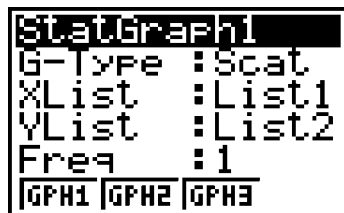

QUIT

F1 (GRPH)

F1 (GPH1)

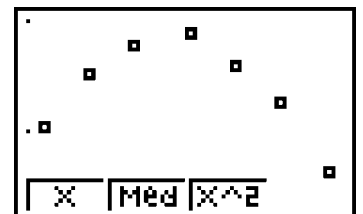

Stat Graph 1: Make List 2 the YList.

Graph 1

3. Engine Speed – Output Graph: Graph 2

QUIT

F1 (GRPH)

▶

F4 (SET)

```
StatGraph2
G-Type :Scat
XList  :List1
YList  :List3
Freq   :1
List1|List2|List3|List4
```

Stat Graph 2: Make List 3 the YList.

QUIT

F1 (GRPH)

F2 (GPH2)

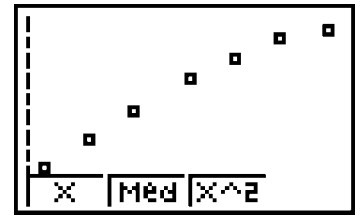

Graph 2

4. Engine Speed – Fuel Efficiency Graph: Graph 3

QUIT

F1 (GRPH)

▶

F4 (SET)

```
StatGraph3
G-Type :Scat
XList  :List1
YList  :List4
Freq   :1
List1|List2|List3|List4
```

Stat Graph 3: Make List 4 the YList.

QUIT

F1 (GRPH)

F3 (GPH3)

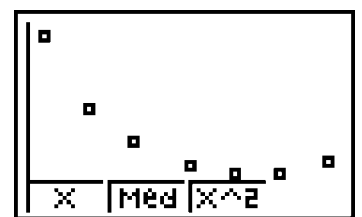

Graph 3

EM-1 Water Depth and Flow Velocity

JIKKYO SHUPPAN CO., LTD.: SHIN KOGYO SURI
(NEW EDITION)

Exercise

Industrial Mathematics (Water Depth and Flow Velocity)

■ Experiment

- (1) Cut off the top of an old oil can. Then, starting 5 cm from the top of can, punch 6mm diameter holes at 5cm intervals into the side of the can, as shown in the illustration.
- (2) First, use tape to cover all the holes except for hole A. Next, fill the can with water so it overflows from the top.
- (3) Allow the water from hole A to flow into a measuring cylinder. Use the stopwatch to measure how long it takes for the water in the cylinder to reach 1000 cm³.
- (4) Repeat the same process for holes B through F, and record the data.
- (5) Use the data obtained to study the relationship between water depth and flow velocity.

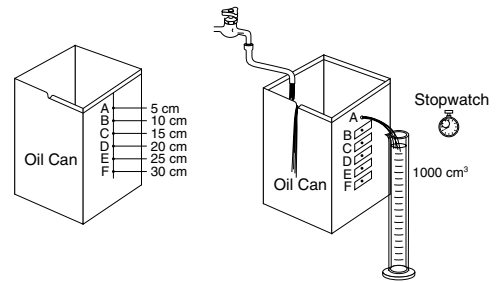

Water Depth h [cm] and Duration t [sec]

Hole	A	B	C	D	E	F
h	5	10	15	20	25	30
t	43.1	30.8	25.8	21.6	20.2	17.9

Exercise 1

When t [s] is the time it takes for 1000 [cm³] to flow from each hole, and Q [cm³/s] is the flow rate and v [cm/s] is flow velocity from each hole, calculate flow rates and the flow velocities.

Solution:

$$Q = \frac{V}{t} \text{ [cm}^3\text{/s]}, \quad v = \frac{Q}{A} \text{ [cm/s]},$$

$$\left(A = \frac{\pi d^2}{4} = \frac{3.14 \times (0.6)^2}{4} = 0.283 \text{ [cm}^2] \right)$$

A: area of a hole.
d: diameter of a hole.

Graphic Calculator Operation

- (1) In the STAT Mode, input the h data into List 1 and the t data into List 2 as shown in the illustration to the right.

	List 1	List 2
1	5	43.1
2	10	30.8
3	15	25.8
		43.1

GRAPH/CALC | SRTA | SRTD

- (2) Input the calculation formula for v into List 3.

Calculation: $(1000 \div \text{List 2}) \div 0.283$

Move the cursor to the List 3 title and input the formula.

Use **OPTN** **F1** (LIST) **F1** (List) to input the List characters.

	List 2	List 3
1	43.1	
2	30.8	
3	25.8	

(1000÷List 2
List | MEM | DIM | FILL

(3) This makes it possible to obtain flow velocity v in List 3.

	List 2	List 3
1	43.1	81.985
2	30.8	114.72
3	25.8	136.96
		81.98535742
	List	MEM Dim Fill

Exercise 2

From the data in Exercise 1, graph the relationship between water depth h [cm] and flow velocity v [cm/s].

Solution:

With the h [cm] on the horizontal axis and v [cm/s] on the vertical axis, point data points and then draw a regression curve.

Graphic Calculator Operation

(1) From the Main Menu, enter the STAT Mode.

(2) Assign List 1 to the X-axis (XList) and List 3 to the Y-axis (YList).

Use **F1** (GRPH) **▶** **F4** (SET) to configure the settings shown in the illustration to the right.

Press **QUIT** **F1** (GRPH) **F1** (GPH1) to draw the graph.

StatGraph1	
G-Type	:Scat
XList	:List1
YList	:List3
Freq	:1
	[GPH1] [GPH2] [GPH3]

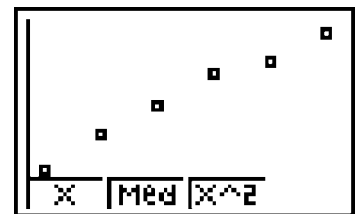

(3) Regression by Function

The formula for this exercise can be expressed as $v = 36.0\sqrt{h}$, which is power regression.

Coefficients can be obtained by **▶** **F3** (Pwr).

F4 (DRAW)

PowerReg	
a=	37.4489
b=	0.48521
r=	0.99873
y=a·x^b	
	[COPY] [DRAW]

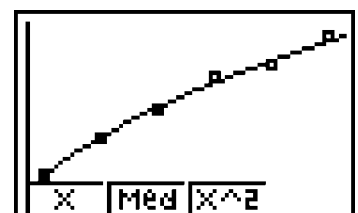

Note

When the hole position is 0 [cm] in this exercise, the flow rate is 0. When $h = 0$ then $v = 0$. Adding this data to the top of the list makes drawing of the regression curve easier.

A-3 Straight Line Passing Through Two Points

Find the equation for the straight line passing through the two points $(-2, 1)$ and $(-1, -4)$.

This problem is easy for students.

The straight line is found by substituting two points $(-2, 1)$ and $(-1, -4)$ into $y = ax + b$, creating a system of simultaneous linear equations with two unknowns (a , and b).

Here we will use a regression line to obtain the result.

From the Main Menu, enter STAT Mode.

Input the following.

List 1	List 2
-2	1
-1	-4

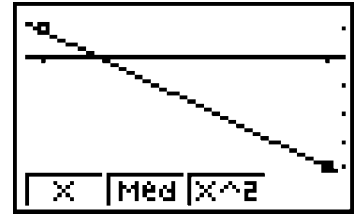

Press **F1** (GRPH) and then select **F1** (GPH1) .

This displays the two points on the screen. The straight line that passes between these two points is the one we are trying to obtain.

Next, press **F2** (X) .

This calculates $a = -5$, $b = -9$ for $y = ax + b$.

Pressing **F3** (COPY) **EXE** substitutes $y = -5x - 9$ for GRAPH. Pressing **F4** (DRAW) draws the straight line.

A-4 Parabola Passing Through Three Points

Find the equation of the parabola that passes through the following three points: $(-2, 1)$, $(-1, -4)$, $(1, 1)$.

This problem is difficult for students.

Here we will use the regression function to obtain the result.

From the Main Menu, enter the STAT Mode.

Input the following.

List 1	List 2
-2	1
-1	-4
1	1

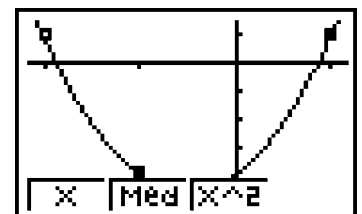

Press **F1** (GRPH) and then select **F1** (GPH1) .

This displays the three points on the screen. The parabola that passes through these three points is the one we are trying to obtain.

Next, press **F3** (X^2) .

This calculates $a = 2.5$, $b = 2.5$, $c = -4$ for $y = ax^2 + bx + c$.

Pressing **F3** (COPY) **EXE** substitutes $y = 2.5x^2 + 2.5x - 4$ for GRAPH.

Pressing **F4** (DRAW) draws the parabola.

S-1 Histogram

Use a graphic scientific calculator to graph statistics.

Exercise 1

The following data represents the distances a handball is thrown by 12 students.

14 20 25 28 18 26 (Unit: meters)
23 21 24 32 15 22

(The Entrance Examination of Hokkaido Public High School, 2000)

Procedure: Input data into List 1. Select the input data and graph type.

Solution: From the Main Menu, enter the STAT Mode.



1. Input data into List 1.

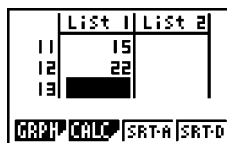
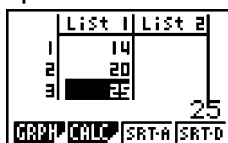

Press **F1** (GRPH) to display the data and graph setting screen.

2. Specify the data and graph.

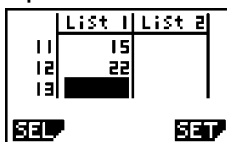
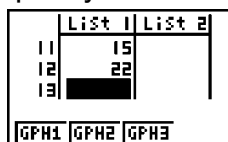

F4 (SET)



*Select G-Type, and press **▶**, **F1** (Hist)

Configure settings as shown above, and then press **EXE**.

3. This draws a histogram.

F1 (GPH1)

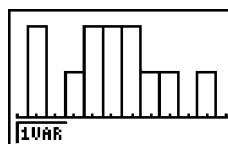

F1 (1VAR)

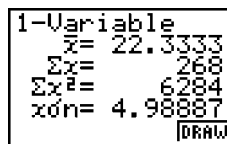

QUIT

4. Pressing **F2** (CALC) calculates the mean and standard deviation of the input data.

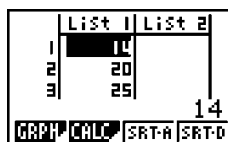

F2 (CALC)

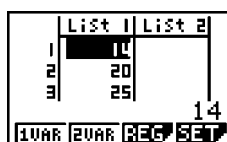

F1 (1VAR)

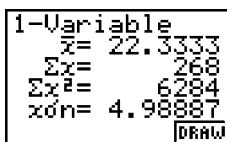

Reference

You can also change the width of the class.

Operation

(1) **SHIFT** **MENU** (SET UP)

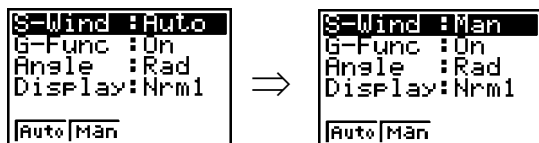

F2 (Man)

The display settings are also changed.

(3) **SHIFT** **F3** (V-WIN)

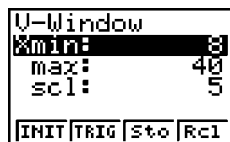

x-axis

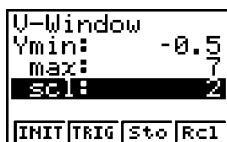

y-axis

(2) Change the start value of the class to 10, and the width to 5.

EXE, **F1** (GRPH), **F1** (GPH1)



10 **EXE** **5** **EXE**



QUIT

(4) Draw the histogram.

EXE, **F1** (GRPH), **F1** (GPH1)

F4 (DRAW)

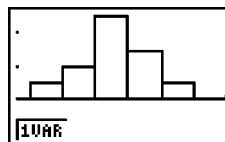

Drill 1

The following shows the results recorded for a side step drill by 25 students. Use the data to draw a histogram. (The Entrance Examination of Yamaguchi Public High School, 2000)

55 34 47 54 39 48 44 37 44 49
 43 40 51 38 43 49 38 45 53 39
 51 47 48 42 56

Abbreviated Solution

*Use List 6.

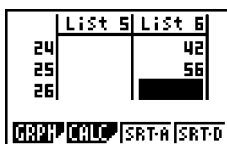

Data Input Start

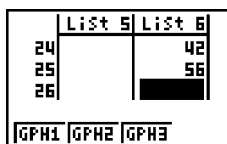

Input Complete



Data and Graph Type Selection

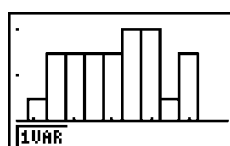

Histogram Display

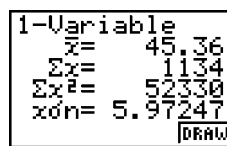

Statistical Data

S-2 Circle Graph

Exercise 2

The data to the right shows the percentages of new subscribers that use various available methods to subscribe to an Internet service provider. Draw a circle graph of this data.

Users Employing Each Provider Subscription Method (%)

Subscription Method	%
From provider Website	28.4
Off-line by mail	27.2
Software that comes with new computer	18.8
CD-ROM provided through a magazine	9.7
CD-ROM distributed through retailers	9.1
CD-ROM requested from provider	6.8
Total	100

(Yahoo! Internet Guide <2002. February>, Japan)

Solution

- Input the data into List 2.

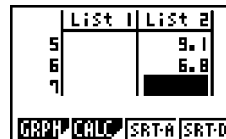
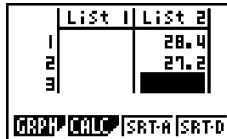
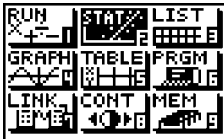

Set up the drawing conditions.

SHIFT **MENU** (SET UP) **F1** (AUTO) **QUIT**

- Select **F1** (GRPH).

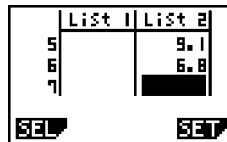
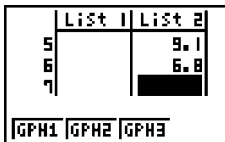

F4 (SET)

Configure settings and press **EXE**.

- Display the circle graph.

Press **F2** (GPH2).

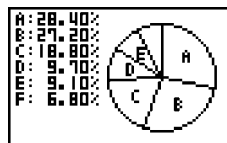

This draws the circle graph.

- Use **F1** (TRCE).

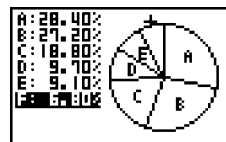
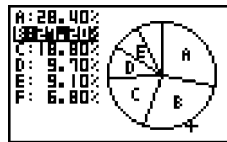
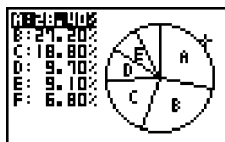

Pressing the round cursor key  moves the pointer in the sequence A → B → C → D → E, and so on.

Drill 2

The nearby table shows Japanese lumber production data by tree type. Create a circle graph of this data. Note that the values shown here are not percents.

Lumber Production in Japan by Tree Type – 1988

Unit: 1,000 mm²

Tree Type	Volume
Japanese Cedar	7788
White Cedar	2338
Fir, Spruce	1609
Red Pine, Black Pine	1581
Larch	1526
Other	372

Drill 2 Solution

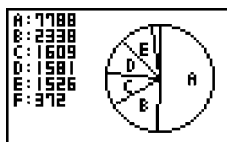

Note the setting for Display.

S-3 Bar Graph

Exercise 3

The nearby table shows the number of people visiting Hawaii from Japan and other countries during June 2000. It shows the total number of visitors on each day of the week.

Day	Total Visitors
SUN	22596
MON	22777
TUE	21962
WED	23481
THU	21662
FRI	23995
SAT	26732

Explanation: Input the data into List 4 and draw a bar graph.

Solution

- Input the data into List 4.

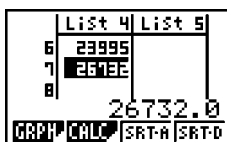

- Press **F1** (GRPH) and configure settings.

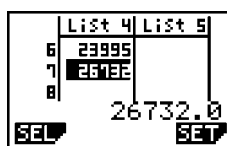
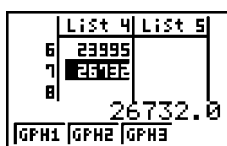

F4 (SET)

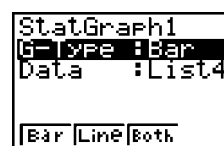

Configure settings as shown above, and then press **EXE**.

- Display the bar graph.

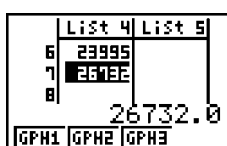

Press **F1** (GPH1) to select Graph 1.

S-4 Bar Graph and Line Graph

Exercise 4

The following shows the monthly average temperature and precipitation for Tokyo.

Tokyo	JAN	FEB	MAR	APR	MAY	JUN	JUL	AUG	SEP	OCT	NOV	DEC
Temperature	5.2	6.6	8.5	14.1	18.6	21.7	25.2	27.1	23.2	17.6	12.8	7.9
Precipitation	45.1	80.4	60.4	99.5	125.0	138.0	185.2	126.1	147.5	179.8	89.1	45.7

Use this data to draw a graph that includes a bar graph of the precipitation and a line graph of the temperature.

Explanation When specifying the data graph type, select **F3** (Both).

Solution

1. Input the data into any available lists. In this exercise, we input the data into List 5 and List 6.

	List 5	List 6
11	12.8	89.1
12	7.9	45.7
13		

List 5: Temperature
List 6: Precipitation

	List 5	List 6
11	12.8	89.1
12	7.9	45.7
13		

Press **F1** (GRPH)
and then **▶**.

	List 5	List 6
11	12.8	89.1
12	7.9	45.7
13		

Press **F4** (SET).

2. Specify the data and graph.

StatGraph1
G-Type: Both
Bar: List6
Line: List5
AutoWin: Sep.G
Scat: XY Pie: Stck

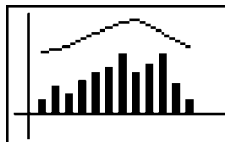

▶ ▶ ▶ ▶
Select **F3** (Both)
for G-Type.

The bar graph shows the precipitation data in List 6.
The line graph shows the temperature data in List 5.

Drill 4

The nearby table shows the volume of PET bottles produced in Japan and the percentage of bottle recycled during each year. Draw a bar graph that shows the production volume, together with a line graph that shows the recycle rate.

PET Bottle Production Volume (t) and Recycle Rate (%)

	Production Volume	Recycle Rate
1993	123,798	0.4
1994	150,282	0.9
1995	142,110	1.8
1996	172,902	2.9
1997	218,806	9.8
1998	281,927	16.9
1999	332,202	22.8
2000	361,944	31.8

Drill 4 Solution

	List 1	List 2
7	332202	22.8
8	361944	31.8
9		

GRPH CALC SRT-A SRT-D

	List 1	List 2
1	123798	0.4
2	150282	0.9
3	142110	1.8
		123798.0

GPB1 GPB2 GPB3

Change the settings.

Press **F1** (GRPH), **▶**, and then **F4** (SET).

StatGraph1
G-Type :Both
Bar :List1
Line :List2
AutoWin:Sep.G
SEP.G O.Lap Norm

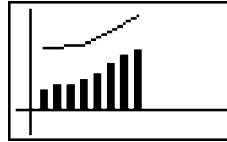

When **F1** (Sep.G) is selected for AutoWin.

StatGraph1
G-Type :Both
Bar :List1
Line :List2
AutoWin:O.Lap
SEP.G O.Lap Norm

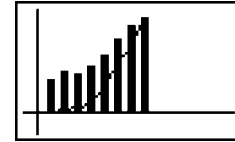

When **F2** (O.Lap) is selected for AutoWin.

EE-1 Relationship Between Voltage, Current, and Power

Exercise

Application 1

The following table shows voltage, current, and power measurements on a given circuit. Draw a graph that shows the relationship among the three measurements.

Measured Results

Voltage (V)	Current (A)	Power (W)
0	0	0
10	0.2	2.0
20	0.24	4.8
30	0.27	8.1
40	0.31	12.4
50	0.36	18.0
60	0.39	23.4
70	0.43	30.1
80	0.46	36.8
90	0.49	44.1
100	0.52	55.2

Graphic Calculator Operation

1. In the STAT Mode, input the data shown below.

List 1 = Voltage (V)

List 2 = Current (A)

List 3 = Power (W)

You do not need to input zeros as the initial values for voltage, current, and power.

2. Voltage – Current

Make voltage (List 1) the XList, and current (List 2) the YList, and then draw a regression curve. Then press **F1** (X) and **F4** (DRAW) .

The virtually straight line indicates a linear expression (proportionality).

3. Voltage – Power

Graph voltage (List 1) for XList and power (List 3) for YList. This line is curved, which means regression can be performed using a range of points of second order. (Press **F3** (X²) and **F4** (DRAW) .)

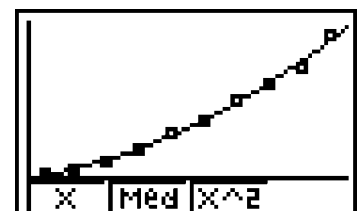
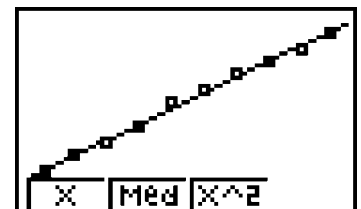
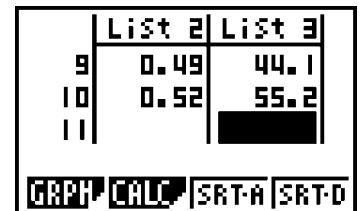

EE-2 Ohm's Law

Ohm's law deals with the relationship between current, voltage, and resistance.

The following expressions express this relationship, when I is current, R is resistance, and E is voltage.

$$I = E / R \quad R = E / I \quad E = IR$$

■ Proportional Expression

The proportional expression is $y = ax$, where a is the constant of proportion. Doubling or tripling x causes the y value to double or triple.

The following is the graph of the relationship between x and y .

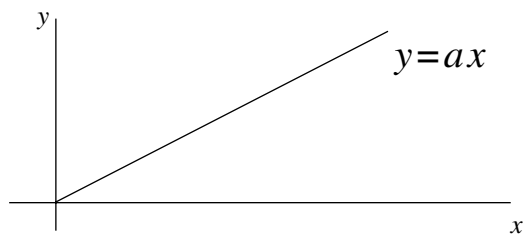

The a variable in the proportional expression has a linear slope. The larger its value, the greater the slope of the line is.

The graphs of $y = 0.5x$ and $y = 2x$ are shown below.

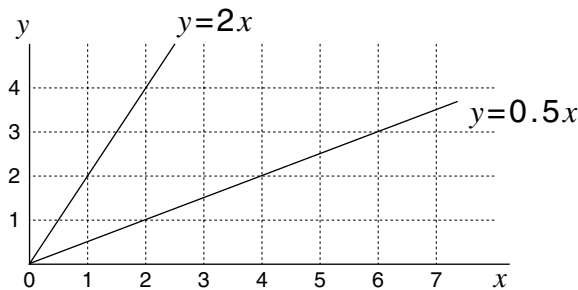

We can use these graphs to obtain the value of a . If the proportional expression graph passes through a point where $y = 9$ and $x = 3$ (coordinates $(3, 9)$), for example, the value of a is:

$$9 = a \times 3$$

$$a = 3$$

This means that the linear expression is $y = 3x$.

Determine the slopes of the graphs shown below.

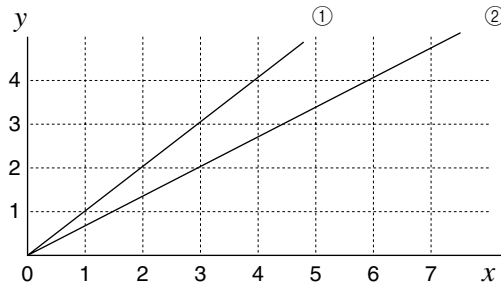

Expression ①

$$4 = a \times 4$$

$$a = 1$$

$$\text{Therefore: } y = x$$

Expression ②

$$2 = a \times 3$$

$$a = 2/3$$

$$\text{Therefore: } y = 2x/3$$

■ Back to Ohm's Law

Getting back to Ohm's Law, consider the relationship $I = E/R$. Compare this with the $y = ax$ proportional expression we discussed on the previous page.

If we substitute I for y and E for x , a becomes $\boxed{1/R}$.

This results in the proportional expression $I = \boxed{1/R} E$. If R is constant, then I is proportional to E . In other words, doubling or tripling the voltage value also causes the current value to double or triple.

Experiment 1

Now let's perform an experiment that actually checks the theory behind Ohm's Law. Prepare a circuit with 100Ω resistors like the one shown below.

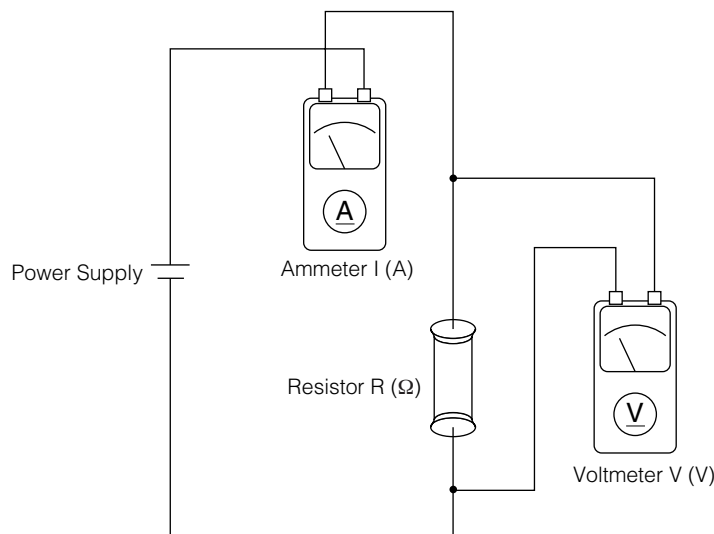

Let's try gradually increasing the voltage of the power supply. Measure voltage and current on either side of the resistor. Raising voltage from 0V to 2V, in 0.2V steps, record the current values.

- Do not raise power supply voltage higher than 6V!
- The resistor will become hot during this experiment. Be careful!

Experiment 1 Results

Voltage (V)	0	0.2	0.4	0.5	0.6	0.8	1.0	1.2	1.4	1.6	1.8
Current (mA)	0	2.0	4.0	6.0	8.1	10.2	12.1	14.2	16.2	18.2	20.3

Analysis – Step 1

Use your graphic calculator to graph the results shown in the table. In the STAT Mode, input the Voltage data into List 1, and the Current data into List 2. Input current value in (A) units instead of (mA) units.

Analysis – Step 2

Now it's time to move on to the next step, which is to determine the slope of this graph. Your graphic calculator can calculate the slope for you automatically.

The slope of the graph is 1.02×10^{-2} .

Analysis – Step 3

Now let's recall our original expression: $I = \frac{1}{R} E$. The slope we obtained should be approximately the same as the value of $\frac{1}{R}$. Let's check if it is. Remember that the resistance value we used in the experiment is 100Ω .

Experiment 2

Referring to Experiment 1, determine unknown resistance values. We will use three resistors, each of which has four colored bands.

■ Resistor 1 (Brown, Green, Brown, Gold)

Voltage (V)	0	0.2	0.4	0.6	0.8	1.0	1.2	1.4	1.6	1.8	2.0
Current (mA)	0	1.4	2.7	4.1	5.5	6.8	8.2	9.6	10.9	12.3	13.6

Analysis – Step 1

Input the data on your graphic calculator and graph it.

Analysis – Step 2

Use the graphic calculator to determine the slope of the line.

$$a = 6.81 \times 10^{-3}$$

Analysis – Step 3

Determine the resistance value.

$$R = 147\Omega$$

■ Resistor 2 (Yellow, Violet, Brown, Gold)

Voltage (V)	0	0.2	0.4	0.6	0.8	1.0	1.2	1.4	1.6	1.8	2.0
Current (mA)	0	0.43	0.86	1.3	1.7	2.2	2.6	3.0	3.5	3.9	4.3

Analysis – Step 1

Input the data on your graphic calculator and graph it.

Analysis – Step 2

Use the graphic calculator to determine the slope of the line.

$$a = 2.16 \times 10^{-3}$$

Analysis – Step 3

Determine the resistance value.

$$R = 463\Omega$$

■ Resistor 3 (Violet, Green, Black, Gold)

Voltage (V)	0	0.2	0.4	0.6	0.8	1.0	1.2	1.4	1.6	1.8	2.0
Current (mA)	0	2.8	5.6	8.3	11.1	13.8	16.5	19.2	21.8	24.5	27.3

Analysis – Step 1

Input the data on your graphic calculator and graph it.

Analysis – Step 2

Use the graphic calculator to determine the slope of the line.

$$a = 13.6 \times 10^{-3}$$

Analysis - Step 3

Determine the resistance value.

$$R = 74\Omega$$

Other Things To Do 1

After determining the resistance values of all three resistors, check their actual values using the resistor color code chart below.

Other Things To Do 2

There is some difference between the resistance values calculated in the experiment and actual resistance values. What is the reason for this difference?

Resistor Color Code Chart

Color	Value	Multiplier	Tolerance (%)
Black	0	1	—
Brown	1	10	±1
Red	2	10 ²	±2
Orange	3	10 ³	—
Yellow	4	10 ⁴	—
Green	5	10 ⁵	±0.5
Blue	6	10 ⁶	±0.25
Violet	7	10 ⁷	±0.1
Gray	8	10 ⁸	—
White	9	10 ⁹	—
Silver	—	10 ⁻²	±10
Gold	—	10 ⁻¹	±5
None	—	—	±20

Experiment 3

Experiment 1 and Experiment 2 used resistors (carbon film resistors). In Experiment 3, we will use a light bulb in place of resistance, whose filament acts as the resistance. Wire a diagram like the one shown below.

- Raising power supply voltage too high makes the light bulb very bright and very hot!
- Do not raise power supply voltage over 4V.

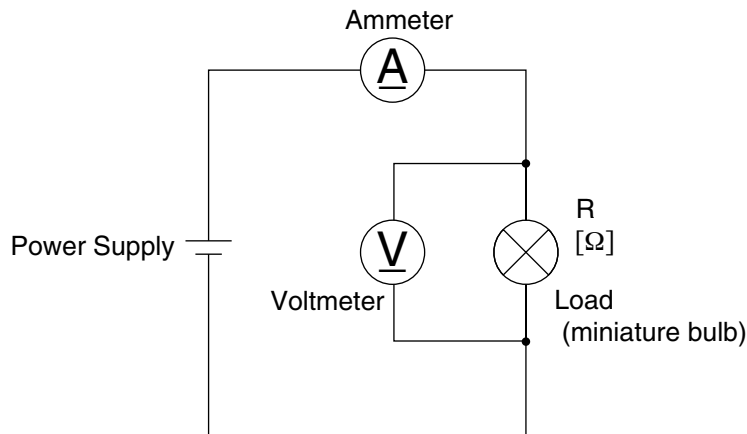

As with the previous experiments, this experiment studies the relationship between voltage and current.

Gradually raise the power supply voltage, measuring voltage and current on either side of the light bulb. Raise the power supply voltage from 0V to 2V, in 0.2V increments, recording current values as you go.

Experiment 3 Results

Voltage (V)	0	0.2	0.4	0.6	0.8	1.0	1.2	1.4	1.6	1.8	2.0
Current (A)	0	0.30	0.42	0.48	0.53	0.57	0.60	0.63	0.66	0.69	0.72

Analysis – Step 1

Use your graphic calculator to graph the results. In the STAT Mode, input the Voltage data into List 1, and the Current data into List 2.

Analysis – Step 2

Now it's time to move on to the next step. Is the graph produced by this Experiment different from the graphs produced in Experiment 1 and Experiment 2? Write what you observe.

The points in the graphs produced by Experiments 1 and 2 are linear and pass through the origin, but the Experiment 3 graph is not linear.

Analysis – Step 3

The shapes of the graphs produced when resistors are used differ from the graph produced by the light bulb. In the case of resistors, the graph is linear and passes through the origin, but the light bulb resistance graph is different. What does this tell you about the resistance of a light bulb? Write down your thoughts.

The resistance of the light bulb increases as the voltage applied rises.

- What causes the phenomena we observed in Analysis - Step 3?

As voltage increases, more current flows through the filament, causing it to become hotter.

EE-3 Small Signal Amplification Factor of a Transistor

Objective

The “Experiment Corner: Finding the small signal current amplification ratio h_{fe} of a transistor” in JIKKYO SHUPPAN Co., Ltd. “DENSHI KISO (NEW EDITION) 719” provides a practical example of using a graphic calculator. Since the functions used are limited to basic operations, they can be incorporated into an actual classroom setting quite easily.

Worksheets are provided to allow the experiment to be performed in the classroom.

Worksheets include information about how to use a graphic calculator as the experiment progresses.

Experiment Corner:

Finding the small signal current amplification ratio h_{fe} of a transistor

1. About transistor names

The following are the names of the transistor we will be using for this experiment:

2SC1815 and **2SD1763**.

Write the meanings of these symbols (numbers).

2. Connecting devices

Connect the variable resistor VR, 10k Ω resistor, DC ammeter, transistor, and battery as shown in the circuit diagram below.

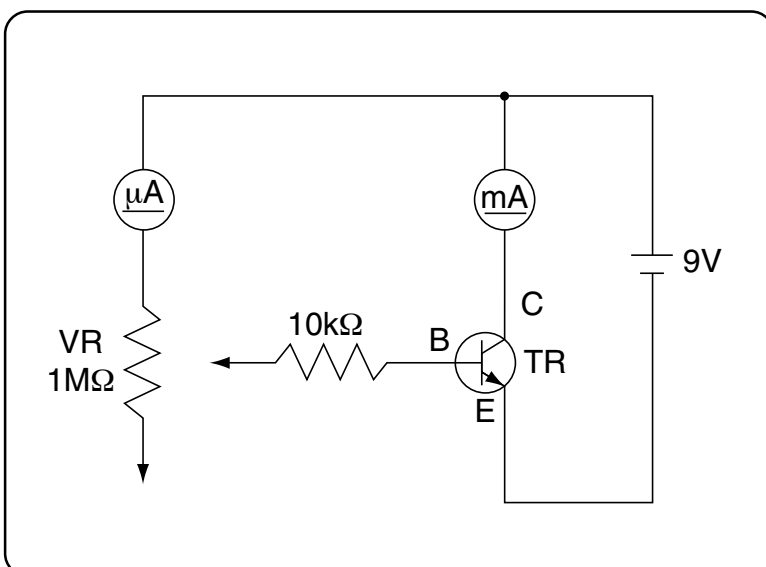

Connection Precautions

- Make sure you connect the transistors collector, base, and emitter correctly.
- Make sure you orient the battery's positive and negative poles correctly.
- Set the variable resistor to its maximum resistance value.

3. What is the small signal current amplification ratio h_{fe} ?

The small signal current amplification ratio h_{fe} expresses how much collector-emitter current increases during transistor operation when base current is increased slightly.

$$h_{fe} = \frac{\hspace{10em}}{\hspace{10em}} = \frac{\hspace{10em}}{\hspace{10em}}$$

4. Measurement

- (1) First, measure transistor 2SC1815. Connect it to the circuit.
- (2) Adjust variable resistor VR to allow collector-emitter current to flow, and record base current at that time. Increase and measure current up to 2mA in about 0.1mA steps.

Collector-emitter Current (mA)	
Base Current (μA)	

5. Drawing the graph

Use a graphic calculator to graph the results with base current on the horizontal axis and collector-emitter current on the vertical axis.

Operation

Data Input

From the Main Menu, enter the STAT mode.

After confirming that the cursor is located in line 1 of List 1, input base current values.

Example: 9 [EXP] [←] 6 [EXE]
 10 [EXP] [←] 6 [EXE]
 11 [EXP] [←] 6 [EXE] ... etc.

After confirming that the cursor is located in line 1 of List 2, input collector-emitter current values.

Example: 3.17 [EXP] [←] 3 [EXE]
 3.57 [EXP] [←] 3 [EXE]
 3.86 [EXP] [←] 3 [EXE] ... etc.

	List 1	List 2
1	9E-6	3.1E-3
2	1E-5	3.5E-3
3	1.1E-5	3.8E-3
		9-06
	GPH1	GPH2 GPH3

Graph Settings

Press **F1** (GRPH) **▶** **F4** (SET) to check the graph settings. Use **▲** and **▼** to move the cursor around the display and use keys **F1** through **▶** to change the settings to they are like the ones shown on the screen nearby.



Graphing

Press **QUIT** **F1** (GRPH) **F1** (GPH1) to display the graph (scatter diagram).



Data Editing

- To change data, move the cursor to the data you want to change and over write it with the correct data.
- To insert data, move the cursor to the location of the insert, and then press **▶** **F3** (INS).
- To delete data, move the cursor to the data you want to delete, and then press **▶** **F1** (DEL).
- To return from the graph screen to the data input screen, press **QUIT**.

6. Analyzing data

The small signal current amplification ratio h_{fe} of the transistor is .

This is represented as on the graph.

You can calculate the slope of the line on the graphic calculator automatically.

Calculation of the slope and other information from the obtained data is performed using linear regression. Though the actual calculation is quite complex and difficult to perform, the graphic calculator performs linear regression in an instant and provides the slope and y-intercept.

Graphing

Press **QUIT** **F1** (GRPH) **F1** (GPH1) to display the graph (scatter diagram).



Linear Regression

Pressing **F1** (X) **F4** (DRAW) performs linear regression and overlays it onto the scatter diagram as shown on the screen nearby. Pressing **F1** displays the slope, which is the value indicated for "a=".

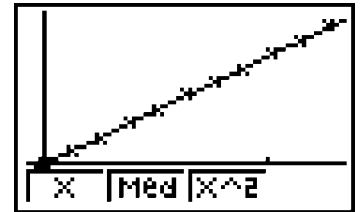

This result indicates that the following is the small signal current amplification ratio of transistor 2SC1815.

$$h_{fe} = \boxed{}$$

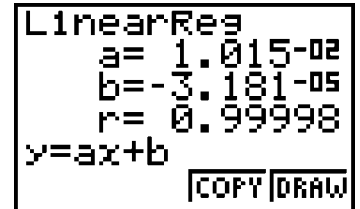

Use the same procedure to determine the small signal current amplification ratio h_{fe} of transistor 2SD1763.

(1) Measure values.

- Input measurement results into the table below.

Collector-emitter Current (mA)	
Base Current (μ A)	

(2) Graph the results.

- Without deleting the previous data, input the base current into List 3 and the collector-emitter current into List 4.
- Draw the graph. Select List 3 for the X-axis and List 4 for the Y-axis.

(3) Determine the small signal current amplification ratio h_{fe} .

- Use the graphic calculator's linear regression function to calculate h_{fe} .

$$h_{fe} = \boxed{}$$

7. Things to think about

What transistor characteristics become evident from this experiment?

8. Write down your feelings about this experiment

9. Topic

A transistor works the same way as a vacuum tube. Summarize the difference between the structure of a vacuum tube and a transistor.

10. Supplement

The 2SD1763 used in this experiment is a transistor that is used when large output is required, such as for a speaker. This type of transistor is called a power transistor.

EC-1 Density of a Liquid

In exercises that involve measurements, the most common approach is to perform calculations and draw graphs based on measurement results, and then to study tendencies, estimated values, and other factors. This exercise is a practical application of a physical chemistry exercise (physical measurement) using the graphic calculator.

Among physical chemistry exercise types are those that measure the physical properties of liquid. These types of exercises measure density, viscosity, surface elasticity, index of refraction, angle of rotation, etc. All such exercises measure physical properties as the concentration of a liquid changes, and graphs the changes in order to make estimates and to study various properties affected by the changes.

The practical exercise presented here shows how to graph measurement results.

Exercise

Measuring the Density of a Liquid

Solutions of ethanol and water are prepared in concentrations of 0, 20, 40, 60, 80, and 100 wt%. Each sample is poured into a specific gravity flask, its mass is measured under constant temperature, and the density of each is calculated. Results are used to create and study a concentration – density curve.

Results (Example)

Table 1 — Measurement Results

Sample Number	Ethanol Concentration (wt%)	Specific Gravity Flask + Sample Mass m_2 (g)
1	0 (Water)	21.0233
2	20	20.6962
3	40	20.3251
4	60	19.8745
5	80	19.3807
6	100	18.8342

Table 2 — Calculation Results

Ethanol Concentration (wt%)	Density ρ (g/cm ³)
0	0.9940
20	0.9615
40	0.9246
60	0.8798
80	0.8308
100	0.7765

When the specific gravity flask mass $m_0 = 11.0205$ (g) and the density of water ρ_w is 0.9940 (g/cm³), the volume of the specific gravity flask is:

$$V = \frac{m_1 - m_0}{\rho_w} = \frac{21.0233 - 11.0205}{0.9940} = 10.063 \text{ [cm}^3\text{]}$$

Sample solution density ρ (g/cm³) is the following:

$$\rho = \frac{m_2 - m_0}{V} = \frac{m_2 - m_0}{m_1 - m_0} \times \rho_w = \frac{m_2 - 11.0205}{21.0233 - 11.0205} \times 0.9940 \text{ [g/cm}^3\text{]}$$

Graphic Calculator Operation

1-1. Data Input

From the Main Menu, enter the STAT Mode, and then input the concentration values into List 1 (0 to 100).

Also, input the measurement results (mass) into List 2.

	List 1	List 2
1	0	21.023
2	20	20.696
3	40	20.325

GRAPH/CALC | SRTA | SRTD

1-2. Concentration-Mass Relationship (Scatter Diagram)

After preparing the graph with **F1** (GRPH), press **F1** (GPH1) to display the scatter graph, which shows changes in concentration and mass.

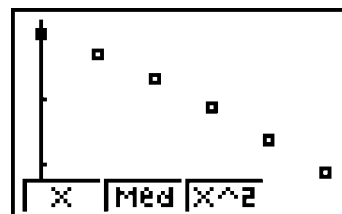

1-3. Density Calculation

Press **QUIT**, and then obtain the density in List 3.

Move the cursor to the List 3 name, and then input Expression 1 as described below.

	List 2	List 3
1	21.023	
2	20.696	
3	20.325	

DEL DEL INS

Press **OPTN** to enable input into the list name, and then input $(\text{List 2} - 11.0205) \div (21.0233 - 11.0205) \times 0.9940$ **EXE**.

F1 (LIST) **F1** (List)

	List 2	List 3
1	21.023	0.994
2	20.696	0.9614
3	20.325	0.9246
		0.994

List LMP Dim Fill

1-4. Density-Concentration Relationship (Scatter Diagram)

Press **QUIT** and perform the following key operation to specify concentration (List 1) for the horizontal axis and density (List 3) for the vertical axis.

Press **F1** (GRPH) **F4** (SET). On the statistical graph setup screen, specify List 3 for YList. (**▼** **▼** **▼**)

F3 (List3) **EXE**

StatGraph1
G-Type : Scat
XList : List1
YList : List3
Freq : 1
List1 List2 List3 List4

Pressing **F1** (GPH1) displays the scatter diagram.

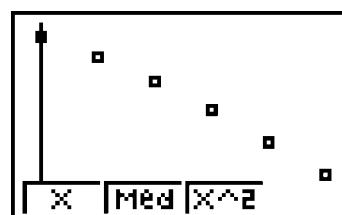

1-5. Linear Regression

F1 (X) displays the linear regression calculation result.

F4 (DRAW) draws the regression graph.

Linear Reg
a = -2.178-03
b = 1.00343
r = -0.99555
y = ax + b
COPY DRAW



a , b are linear coefficients. r is the correlation coefficient.

1-6. Quadratic Regression

After pressing **QUIT** to exit the graph screen, press **F1** (GRPH) **F1** (GPH1) again.

Next, press **F3** (X²) to display the quadratic regression result.

```
QuadReg
a=-7.043-06
b=-1.473-03
c= 0.99404
y=ax2+bx+c
COPY DRAW
```

F4 (DRAW) draws the quadratic regression graph.



This shows that quadratic regression is appropriate for this exercise.

1-7. Data Estimation Using Regression

The results can be used to estimate the density of a 50% ethanol solution as follows.

$$(-7.026 \times 10^{-6}) \times 50^2 + (-1.475 \times 10^{-3}) \times 50 + 0.99405 = 0.902735$$

The above is performed in the RUN Mode.

```
(-7.026E-6)X5
02+(-1.475E-3
)X50+0.99405
0.902735
```

1-8. Copy of Regression Graph to Graph Menu

You can use **F3** (COPY) to copy the nearby screen from step 1-6 to the graph menu.

After using the graph menu to display a graph, you can use the trace mode to determine the value of Y for any value of X.

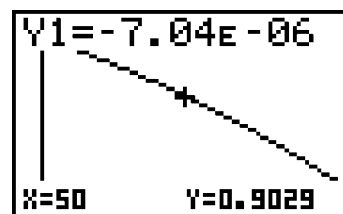

Use **SHIFT F1** (TRCE) to move the cursor. The sample screen shows the value of Y when the cursor is moved to X = 50. This is virtually the same value obtained in step 1-7.

EC-2 Viscosity of a Liquid

Exercise

Measuring the Viscosity of a Liquid

Solutions of ethanol and water are prepared in concentrations of 0, 20, 40, 60, 80, and 100 wt%. An Oswald viscometer is used to measure the flow time and determine the viscosity of each sample. Results are used to create and study a concentration - viscosity curve.

Results (Example)

Ethanol Concentration (wt%)	Viscosity η (mPas)
0	0.7192
20	1.180
40	1.533
60	1.511
80	1.239
100	0.900

Graphic Calculator Operation

2-1. Determination of Maximum Value

As in 1-1 and 1-6 of EC-1 (Density of a Liquid), select the STAT Mode, input the data, and draw the regression curve.

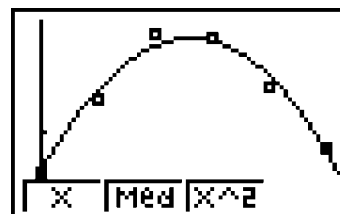
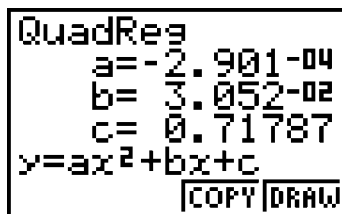
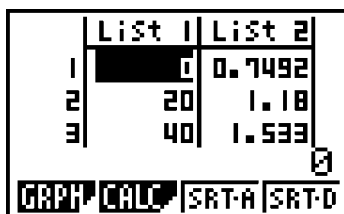

This type of “viscosity measurement graph” exhibits a quadratic curve form. By determining the maximum value (peak) of this regression curve yields the concentration at which maximum viscosity is achieved as well as the viscosity at that point.

As in 1-8, display the graph of the regression expression copied to the graph menu and then press **SHIFT** **F1** (TRCE) to move the cursor to $X = 52.82$. This reveals that the maximum value of Y is 1.5197.

You can also obtain the maximum value as shown below.

$$y' = 2ax + b = 0 \rightarrow x = -\frac{b}{2a}$$

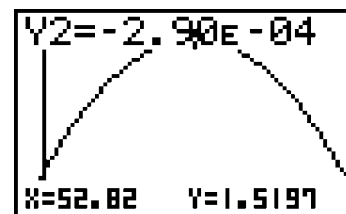

Quadratic Regression Values

$$a = -2.901 \times 10^{-4}, b = 0.03052, c = 0.7179$$

$$\text{Calculation } -\frac{b}{2a} = -\frac{0.03052}{2 \times (-2.901 \times 10^{-4})} = 52.6$$

EC-3 Index of Refraction of a Liquid

Exercise

Measuring the Index of Refraction of a Liquid

Solutions are prepared with sucrose concentrations of 0 to 30 wt%. A refractometer is used to measure the index of refraction for of each sample. A juice sample is also measured using the same procedure, and then a graph is used to estimate the sugar concentration of the juice.

Results (Example)

Sucrose Concentration (wt%)	Index of Refraction
0	1.3340
5	1.3419
10	1.3492
15	1.3569
20	1.3650
25	1.3742
30	1.3839
Unknown Sample (Juice)	1.3521

Graphic Calculator Operation

3-1. Determination of Unknown Sample Density from Graph

In the **STAT** Mode, display the measurement results, perform linear regression, and then copy the regression graph to the **GRAPH** menu.

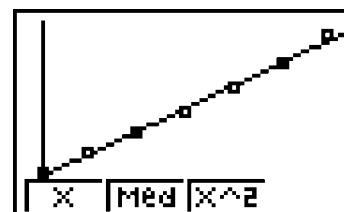

Display the graph you copied to the **GRAPH** menu and determine the concentration for the unknown sample index of refraction 1.3521.

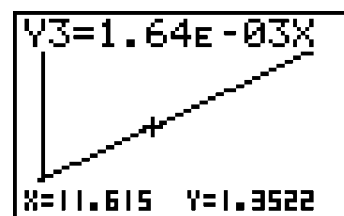

Display the graph and press **SHIFT** **F1** (**TRCE**) to move the cursor. The estimated value of Y when X is as close as possible to 1.3521 (1.3522) is 11.615%.

EC-4 Solubility Curve

Exercise

Industrial Chemistry (1) (Solubility Curve)

The nearby table shows the solubility of potassium nitrate KNO_3 in water. Use this to draw the solubility curve of potassium nitrate.

Temperature (°C)	0	10	20	30	40	50	60	70
Solubility (g/100g water)	13.3	22.0	31.6	45.6	63.9	85.2	109	137

Graphic Calculator Operation

- (1) From the Main Menu, enter the STAT Mode, input temperature into List 1 and solubility into List 2.

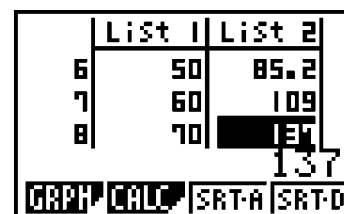

- (2) Scatter diagram

Pressing **F1** (GRPH) **F1** (GPH1) to display the nearby graph.



- (3) Regression curve display

Press **F3** (X^2) to display the regression curve on the range of second order points.

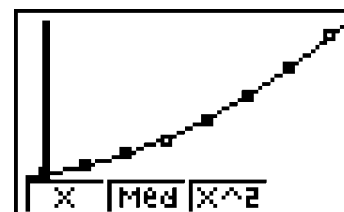

By displaying the graph...

- You can see the changes in the values.
- You can see how the solubility curve changes according to material.
- The regression curve makes it possible to estimate solubility for temperatures not shown in the table and provides data for experiments.

EC-5 Specific Gravity of Gas

Exercise

JIKKYO SHUPPAN CO., LTD.: KOGYO KAGAKU (p. 92)

Industrial Chemistry (2) (Specific Gravity of Gas)

Determine the specific gravity of the following gasses at 0°C, 1 atm.

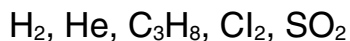

Method 1

Divide the molecular weight of the gas by the average molecular weight of air, which is 29.0

	H ₂	He	C ₃ H ₈	Cl ₂	SO ₂
Molecular Weight M	2	4	41	71	64
$d_0 = M/29.0$					
Density ρ_0	0.0899	0.1785	2.02	3.220	2.926
$d_0 = \rho_0/1.293$					

Method 2

Divide the density of the gas by the density of air, which is 1.293.

Graphic Calculator Operation

The list function of your graphic calculator can be used to determine that the above two methods produce similar results.

(1) Calculation Using Method 1

	List 1	List 2
1	2	
2	4	
3	41	

List 1 ÷ 29
List MEM' Dim Fill

	List 1	List 2
1		0.0689
2		0.1379
3		1.4137

0.0689655172
List MEM' Dim Fill

(2) Calculation Using Method 2

	List 1	List 2
1	0.0899	
2	0.1785	
3	2.02	

List 1 ÷ 1.293
List MEM' Dim Fill

	List 1	List 2
1	0.0899	0.0695
2	0.1785	0.138
3	2.02	1.5622

0.0695282289
List MEM' Dim Fill

M-1 Cam Diagram

Draw the cam diagram of a plate cam with a sliding coupled arm. The cam diagram is created using cam rotation angles input from a multi-turn potentiometer, and from inputting the displacement volumes of the sliding arm. Data is measured with the EA-100 Data Analyzer.



In the above photograph, the displacement of the sliding arm is input from the sliding volume. The illustration to the right is the circuit diagram.

- Slide resistance is large in the case of sliding volume, so a strong spring must be used to press the sliding arm against the cam. Consequently, micro bearings are used to make the movement of all parts smoother.

The potentiometer that inputs the cam rotation angle is a 10-turn type, but a 5-turn or 3-turn type can also be used.

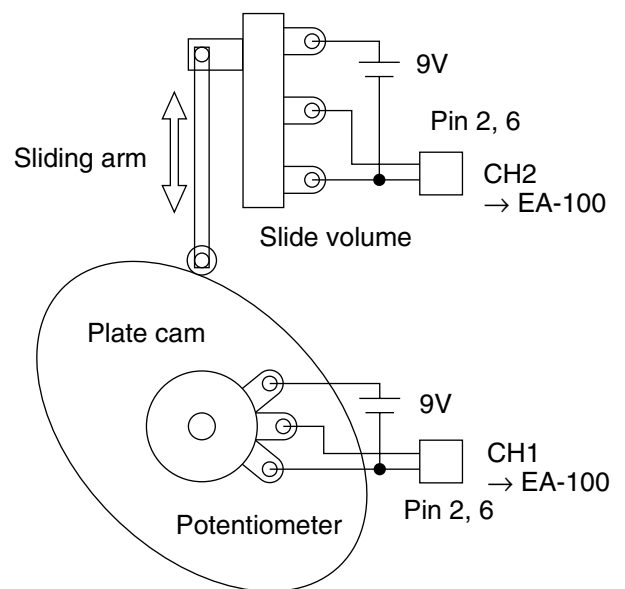

Experiment Results Using the fx-7400G PLUS

After executing the program on the fx-7400G PLUS so screen (1) is on the display, press the EA-100 Data Analyzer **TRIGGER** key. After measurement is complete, press the calculator **EXE** key to display screen (2), followed by screen (3), which is a graph of the cam moving at uniform speed.

(1)

(2)

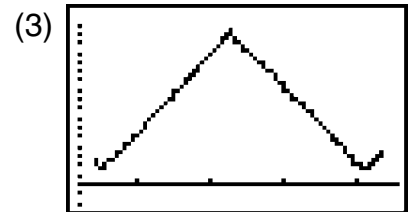

Program

```

Filename:CAM
S-WindAuto ↓
{0} → List 6:Send (List 6) ↓
{1,1,1} → List 6:Send (List 6) ↓
{1,2,1} → List 6:Send (List 6) ↓
{3,0.05,200,0,1} → List 6:Send (List 6) ↓
"DataAnalyzer" ↓
"TRIGGER]Push" ↓
" 10Sec DONE" ↓
"7400EXE]Push" ▲
ClrTxt ↓
"*Please wait*" ↓
ClrList ↓
Receive (List 1) ↓
Receive (List 2) ↓
S-Gph1 DrawOn,xyLine,List1,List2,1,Dot ↓
S-Gph2 DrawOff ↓
S-Gph3 DrawOff ↓
DrawStat

```

Program name: CAM

Specifies auto setup of the graph screen range.

Inputs the data inside {} into List 6, and sends the List 6 data to the Data Analyzer.

{0}: All clear / {1,1,1}:CH1, {1,2,1}:CH2 voltage measurement (0 to 5V) / {3,0.05,200,0,1}: 0.05-second sampling interval, 200 samples, trigger enabled

Displays text within "double quotes."
(Press Data Analyzer **TRIGGER** key.)

Displays "-Disp-" and waits for **EXE** key input.

Clears screen text.

Deletes list data (List 1 to List 6).

Data transferred from Data Analyzer is input to List 1 and List 2.

Graph 1 displays xy (List 1, List 2) graph.
Graph 2 not displayed
Graph 3 not displayed

Graph produced using list data.

Data Analyzer EA-100 Main Commands

Command 0: All clear {0}

Command 1: Channel settings {1, channel, operation}

Channel: 1: CH1, 2: CH2, 3: CH3, 4: SONIC, 5: DIG IN, 6: DIG OUT

Operation: Channel CH1 through CH3: 1: Auto-ID or 0 to 5V voltage measurement, 2: $\pm 10V$ voltage measurement, ...

Channel DIG OUT: Number of data elements and their data

Command 3: Sampling/trigger settings {3, sampling interval, number of samples, recording time, trigger source, ...}

Recording time: 0: Never, 1: Absolute time, 2: Relative time

Trigger source: 0: None (immediate execution), 1: Trigger key, ..., 9: DIG IN 4-bit data

M-2 Stepping Motor Excitation Systems

A 2-phase stepping motor with a step angle of 7.5 degrees is connected to a unipolar drive circuit to observe operation under different excitation systems.

The A phase of the 2-phase stepping motor is connected to DIG-OUT (D0), the B phase is connected to D1, the \bar{A} phase is connected to D2, and the \bar{B} phase is connected to D3 through a drive circuit, and a digital output buffer is used to drive the motor.



The circuit in the upper photograph uses a solid-state relay (SSR) as the unipolar drive circuit. The circuit diagram when using darlington transistors as the drive circuit is shown below.

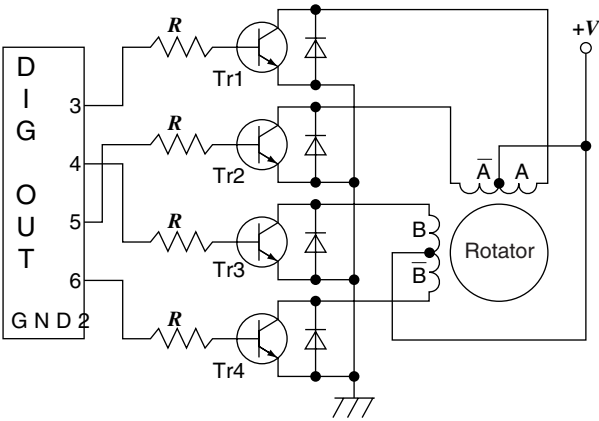

The programs for driving a 2-phase stepping motor and for drawing the charts for each excitation system are shown below.

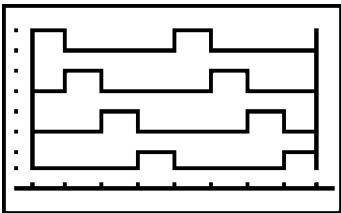

1-phase Excitation System

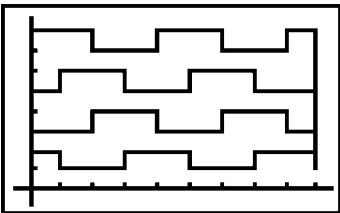

2-phase Excitation System

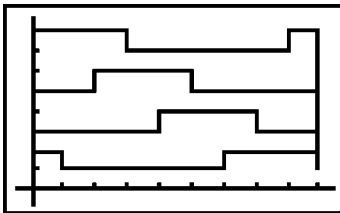

1-2-phase Excitation System

Program for the 1-Phase Excitation System

```

Filename:STEP-1
S-WindAuto ↓
ClrGraph ↓
{0} → List 6:Send (List 6) ↓
{1,6,4,1,2,4,8} → List 6:Send (List 6) ↓
{3,0.2,48,0,0} → List 6:Send (List 6) ↓

{1,1,2,2,5,5,6,6,9,9,9,9,8,8,7,7,4,4,3,3,1} → List 1 ↓
{7,8,8,7,7,8,8,7,7,8,2,3,3,4,4,3,3,4,4,3,3} → List 2 ↓
{9,7,7,6,6,3,3,2,2,1,1,1,4,4,5,5,8,8,9,9} → List 3 ↓
{5,5,6,6,5,5,6,6,5,5,7,1,1,2,2,1,1,2,2,1} → List 4 ↓
S-Gph1 DrawOn,xyLine,List 1,List 2,1,Dot ↓
S-Gph2 DrawOn,xyLine,List 3,List 4,1,Dot ↓
S-Gph3 DrawOff ↓
DrawStat

```

- Program name: STEP-1
- Specifies auto setup of the graph screen range.
- Clears the graph.
- Inputs the data inside {} into List 6, and sends the List 6 data to the Data Analyzer. {0}: All clear / {1,6,4,1,2,4,8}: Sends 4 data elements to DIGOUT. / {3,0.2,48,0,0}: 0.2-second sampling interval, 48 samples, trigger disabled (immediate execution)
- Graph data
- Graph 1 is *xy* (List 1, List 2) graph.
Graph 2 is *xy* (List 3, List 4) graph.
Graph 3 not displayed
Graph produced using list data.

Program for the 2-Phase Excitation System

```

Filename:STEP-2
S-WindAuto ↓
ClrGraph ↓
{0} → List 6:Send (List 6) ↓
{1,6,4,3,6,12,9} → List 6:Send (List 6) ↓
{3,0.2,48,0,0} → List 6:Send (List 6) ↓

{0,0,2,2,4,4,6,6,8,8,9,9,8,8,6,6,4,4,2,2,0,0} → List 1 ↓
{7,8,8,7,7,8,8,7,7,8,8,3,3,4,4,3,3,4,4,3,3,4} → List 2 ↓
{9,9,7,7,5,5,3,3,1,1,0,0,0,1,1,3,3,5,5,7,7,9,9,9} → List 3 ↓
{6,5,5,6,6,5,5,6,6,5,5,7,2,2,1,1,2,2,1,1,2,2,1,3} → List 4 ↓
S-Gph1 DrawOn,xyLine,List 1,List 2,1,Dot ↓
S-Gph2 DrawOn,xyLine,List 3,List 4,1,Dot ↓
S-Gph3 DrawOff ↓
DrawStat

```

- Program name: STEP-2
- {1,6,4,3,6,12,9}: Sends 4 data elements to DIGOUT. / {3,0.2,48,0,0}: 0.2-second sampling interval, 48 samples, trigger disabled (immediate execution)
- Graph data

Program for the 1-2-Phase Excitation System

```

Filename:STEP-1-2
S-WindAuto ↓
ClrGraph ↓
{0} → List 6:Send (List 6) ↓
{1,6,8,1,3,2,6,4,12,8,9} → List 6:Send (List 6) ↓
{3,0.2,96,0,0} → List 6:Send (List 6) ↓

{0,0,3,3,8,8,9,9,7,7,4,4,0} → List 1 ↓
{7,8,8,7,7,8,8,3,3,4,4,3,3} → List 2 ↓
{9,5,5,2,2,0,0,0,1,1,6,6,9,9,9} → List 3 ↓
{5,5,6,6,5,5,7,2,2,1,1,2,2,1,3} → List 4 ↓
S-Gph1 DrawOn,xyLine,List 1,List 2,1,Dot ↓
S-Gph2 DrawOn,xyLine,List 3,List 4,1,Dot ↓
S-Gph3 DrawOff ↓
DrawStat

```

- Program name: STEP-1-2
- {1,6,8,1,3,2,6,4,12,8,9}: Sends 8 data elements to DIGOUT. / {3,0.2,96,0,0}: 0.2-second sampling interval, 96 samples, trigger disabled (immediate execution)
- Graph data

AC-1 Sum of Products

x	y	xy
2.1	3.5	①
7.8	6.9	②
5.6	1.4	③
		④ Total

Answers

- ① 7.35 ② 53.82 ③ 7.84 ④ 69.01

Calculator Operation

- ① Use the LIST function.
- ② In List 1, input the x values 2.1, 7.8, 5.6.
- ③ In List 2, input the y values 3.5, 6.9, 1.4.

	List 1	List 2
1	2.1	3.5
2	7.8	6.9
3	5.6	1.4

SRT-A SRT-D

- ④ Move the cursor to the title of List 3.
- ⑤ Perform the following key sequence to obtain the value of xy .

OPTN **F1** (LIST) **F1** (List) **1** **X** **F1** (List) **2** **EXE** **QUIT**

	List 2	List 3
1	3.5	
2	6.9	
3	1.4	

List MEM Dim Fill

- ⑥ To obtain a value for “Total,” move the cursor to line 4 of List 3 and input the following.

OPTN **F1** (LIST) **▶** **▶** **F2** (Sum) **▶** **F1** (List) **3** **EXE**

	List 2	List 3
2	6.9	53.82
3	1.4	7.84
4		

Sum List 3
List MEM Dim Fill

	List 2	List 3
3	1.4	7.84
4		69.01
5		

List MEM Dim Fill

Deleting Input Data

- ▶** **F1** (DEL): Deletes a single data item
- ▶** **F2** (DEL•A) **F1** (YES): Deletes all data in the currently selected list.

AC-2 Sum of Products and Mean

x	y	xy
11.4	9	①
11.9	32	②
12.4	53	③
/	⑤ Total	④ Sum
	⑥ Mean	

Answers

- ① 102.6 ② 380.8 ③ 657.2 ④ 1140.6
 ⑤ 94 ⑥ 12.1

Calculator Operation

- ① Use the LIST function.
- ② Input the values for x (11.4, 11.9, 12.4) into List 1.
- ③ Input the values for y (9, 32, 53) into List 2.
- ④ Move the cursor to the top of List 3.
- ⑤ Perform the following key operation to calculate the values of xy .

OPTN **F1** (LIST) **F1** (List) 1 **X** **F1** (List) 2 **EXE** **QUIT**

- ⑥ To calculate the value of “Total,” move the cursor to line 4 of List 2 and then perform the following key operation.

OPTN **F1** (LIST) **▶▶** **F2** (Sum) **▶** **F1** (List) 2 **EXE**

- ⑦ To calculate the value of “Sum,” move the cursor to line 4 of List 3 and then perform the following key operation.

OPTN **F1** (LIST) **▶▶** **F2** (Sum) **▶** **F1** (List) 3 **EXE**

- ⑧ To calculate the value of “Mean,” move the cursor to line 5 of List 3, and then divide the result (Sum) obtained in step ⑦ by the result (Total) obtained in step ⑥.

Perform the following key operation.

1140.6 **÷** **94** **=** **12.134**

Another way of performing the step ⑧ is to move the cursor to the title of List 4 and perform the key operation below.

OPTN **F1** (LIST) **F1** (List) 3 **÷** **F1** (List) 2 **EXE** **QUIT**

AC-3 Sum

	Japanese <i>a</i>	Math <i>b</i>	English <i>c</i>	Total <i>a+b+c</i>
1	68	72	59	①
2	76	95	82	253
3	51	80	47	②
4	49	53	62	164
5	92	83	79	③
Total	336	④	329	⑤ Grand Total

Answers

- ①199 ②178 ③254 ④383
⑤1048

Calculator Operation

- ① Use the LIST function.
- ② Input the values for Japanese *a* (68, 76, 51, 49, 92) and the total (336) into List 1.
- ③ Input the values for Math *b* (72, 95, 80, 53, 83) into List 2.
- ④ Input the values for English *c* (59, 82, 47, 62, 79) and the total (329) into List 3.
- ⑤ To calculate the total for the math scores, move the cursor to line 6 of List 2 and then perform the following key operation.

OPTN **F1** (LIST) **▶** **▶** **F2** (Sum) **▶** **F1** (List) **2** **EXE**

- ⑥ Move the cursor to the top of List 4.
- ⑦ Perform the following key operation to calculate the “Grand Total” value.

OPTN **F1** (LIST) **F1** (List) **1** **+** **F1** (List) **2** **+** **F1** (List) **3** **EXE** **QUIT**

AC-4 Percent

Region	Area (km ²)	Population (Persons)	Population Density (Persons per km ²)
A	78.5	567	①
B	67.2	2478	②
C	31.9	775	③
D	18.8	426	22.66
E	2.3	119	④
F	54.6	1243	⑤

Answers

- ① 7.22 ② 36.88 ③ 24.29 ④ 51.74
⑤ 22.77

Calculator Operation

- ① Use the LIST function.
- ② Input the area values (78.5, 67.2, 31.9, 18.8, 2.3, 54.6) into List 1.
- ③ Input the population values (567, 2478, 775, 426, 119, 1243) into List 2.
- ④ Move the cursor to the top of List 3.
- ⑤ Perform the following key operation to calculate the population density.

OPTN **F1** (LIST) **F1** (List)2 **÷** **F1** (List)1 **EXE** **QUIT**

AC-5 Calculations Including Trigonometric Functions (Function Calculations)

① $25.4 \times \tan 78^\circ 05'$

Answer 120.36

From the Main Menu, enter the RUN Mode.

SHIFT **MENU** (SET UP) **▼** **▼** **F1** (Deg) **QUIT**

```
F-Type : Y=
D-Type : Conct
Angle  : Deg
Display: Fix2
Simplify: Auto
|Y=|Parm
```

25.4 **×** **tan** 78 **OPTN** **▶** **F2** (ANGL) **▶** **F1** (° ' ") 5 **F1** (° ' ") **EXE**

```
25.4x tan 78° 5
      120.36
|0.00| |0.00|
```

② $9.65 \div \cos 28.56^\circ$

Answer 10.99

SHIFT **MENU** (SET UP) **▼** **▼** **F1** (Deg) **QUIT** 9.65 **÷** **cos** 28.56 **EXE**

```
9.65÷cos 28.5
6
      10.99
```

③ $\frac{\tan 0.56 \pi}{1.83}$

Answer -2.86

SHIFT **MENU** (SET UP) **▼** **▼** **F2** (Rad) **QUIT**

```
F-Type : Y=
D-Type : Conct
Angle  : Rad
Display: Nrm1
Simplify: Auto
|Deg|Rad|Gra
```

tan **(** 0.56 **×** **SHIFT** **EXP** (π) **)** **÷** 1.83 **EXE**

```
tan (0.56xπ)÷
1.83
-2.864581192
```

AC-6 Permutation and Combination

$$\textcircled{1} P = \frac{n!}{(n-r)!}$$

n	5	8
r	2	6
P	①	②

Answers

① 20 ② 20160

First, solve for P-①:

5 **OPTN** **F4** (PROB) **F1** ($x!$) **÷** (**5** **-** **2**) **F1** ($x!$) **EXE**

5! \div (5-2)!	20
$x!$ nPr nCr Ran#	

[Calculation Using the Playback Function]

Next, solve for P-②:

▶ 8 **▶** **▶** **▶** 8 **▶** 6 **EXE**

$$\textcircled{2} C = {}_m C_2 \times {}_n C_2$$

m	5	7
n	3	9
C	①	②

Answers

① 30 ② 756

First, solve for C-①:

5 **OPTN** **F4** (PROB) **F3** (${}_n C_r$) 2 **×** 3 **F3** (${}_n C_r$) 2 **EXE**

5C2 \times 3C2	30
$x!$ nPr nCr Ran#	

[Calculation Using the Playback Function]

Next, solve for C-②:

▶ 7 **▶** **▶** **▶** 9 **EXE**

AR-1 Economy of Materials (Cross-sectional Area)

JIKKYO SHUPPAN CO., LTD.: SHIN KOGYO SURI
(NEW EDITION)

Exercise 1

Economy of Materials

You want to form a piece of sheet metal to make a shape like the one shown in the illustration nearby, in order to create the largest possible cross-sectional area. Draw a graph to determine the distance from the edge of the sheet metal where it should be bent in order to produce the largest possible area using a piece of sheet metal that is 20 cm wide.

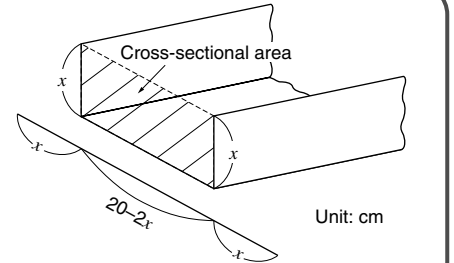

Explanation

When the distance from the edge of the sheet metal to the bend is x (cm) and the cross-sectional area is y (cm²), y can be expressed by the following expression.

$$y = x(20 - 2x) = 20x - 2x^2 \quad (0 < x < 10)$$

Differentiating y by x gives us:

$$y' = 20 - 4x = 4(5 - x)$$

Determining the value of x when $y' = 0$ produces the following:

$$4(5 - x) = 0 \quad x = 5$$

This means that when $x = 5$, the value of y is at its maximum, so the sheet metal should be bent at the two points that are 5 cm from either of its sides.

The following graph shows the relationship between the bend points and cross-sectional area.

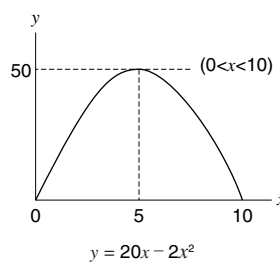

The following is the operation required on a graphic scientific calculator, which also makes the calculation easier to understand.

Operation

• Expression Input

From the Main Menu, enter the GRAPH Mode.

After making sure the cursor is located at Y1:, perform the following key operation.

$$20 \text{ [X,T] } - 2 \text{ [X,T] } x^2 \text{ [EXE]}$$



•Graph Settings

Configure settings for the X-axis and Y-axis ranges and scales.

View Window Settings

Input the X-axis range and scale values shown on the screen nearby.

SHIFT **F3** (V-WIN) **0** **EXE** **10** **EXE** **1** **EXE**

Next, input the Y-axis range and scale values.

▼ **0** **EXE** **100** **EXE** **10** **EXE** **EXE**

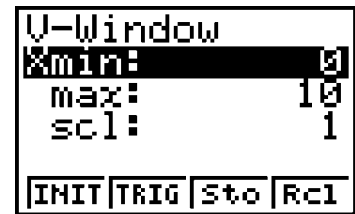

•Graphing

Press **F4** (DRAW) to select DRAW.

This displays a graph like the one shown nearby.

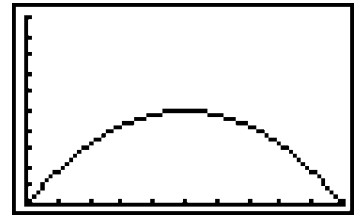

•Trace

Use trace to find out the maximum value.

SHIFT **F1** (TRCE)

Moving the cursor to the apex of the curve reveals that $y = 50$ (the maximum value) when $x = 5$.

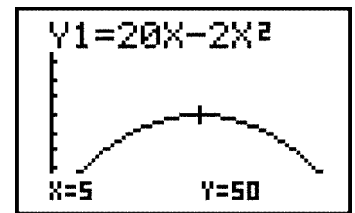

Summary

This exercise shows that the cross-sectional area depends on where the sheet metal is bent. You can determine the best location for the bends by observing where on the X-axis the maximum value of Y is reached.

Check the x and y range settings before performing the operation.

AR-2 Economy of Materials (Volume)

JIKKYO SHUPPAN CO., LTD.: SHIN KOGYO SURI
(NEW EDITION)

Exercise 2

Economy of Materials

When creating a box by cutting out squares of the same size from the four corners of a 30 cm square piece of cardboard, determine the length of each side of the squares that should be cut in order to obtain the greatest volume. Use a graph to check maximum volume.

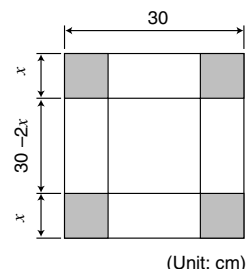

Explanation

When one side of each of the cut out squares is x (cm) and the volume of the box is V (cm³):

$$\begin{aligned} V &= (30 - 2x)^2 x = (900 - 120x + 4x^2)x \\ &= 4x^3 - 120x^2 + 900x \quad (0 < x < 15) \end{aligned}$$

Differentiating V by x gives us:

$$\begin{aligned} V' &= 12x^2 - 240x + 900 \\ &= 12(x^2 - 20x + 75) \\ &= 12(x - 15)(x - 5) \end{aligned}$$

According to this, the value of x when $V' = 0$ produces the following:

$$x = 15, \quad x = 5$$

This means that when $x = 5$, the value of V is 2000 cm³, which is its maximum.

The above expression can be used to draw a graph on a graphic scientific calculator to determine the length of one side of each cut out square.

The following is the operation required on a graphic scientific calculator, which also makes the calculation easier to understand.

Operation

• Expression Input

From the Main Menu, enter the GRAPH Mode.

If a graph appears on the screen, press $\boxed{G\text{-}T}$.

After making sure the cursor is located at Y2:, perform the following key operation.

$$4 \boxed{X,T} \boxed{\wedge} 3 \boxed{-} 120 \boxed{X,T} \boxed{x^2} \boxed{+} 900 \boxed{X,T} \boxed{EXE}$$

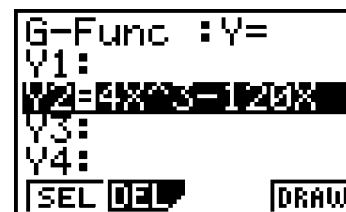

- If there is an expression at Y1, make sure its “ = ” sign is not highlighted. (When the cursor is at Y1, press $\boxed{F1}$ (SEL).)

•Graph Settings

Configure settings for the X-axis and Y-axis ranges and scales.

View Window Settings

Input the X-axis range and scale values shown on the screen nearby.

SHIFT **F3** (V-WIN) **0** **EXE** **15** **EXE** **1** **EXE**

Next, input the Y-axis range and scale values.

▼ **0** **EXE** **2500** **EXE** **500** **EXE** **EXE**

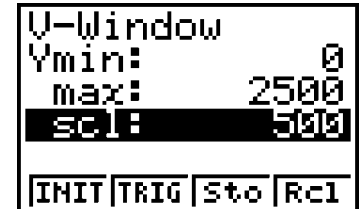
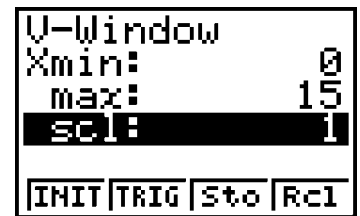

•Graphing

Press **F4** (DRAW) to select DRAW.

This displays a graph like the one shown nearby.

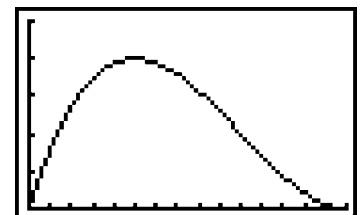

•Trace

Use trace to find out the maximum value.

SHIFT **F1** (TRCE)

Moving the cursor to the apex of the curve reveals that $y = 2000$, the maximum value, when $x = 5$.

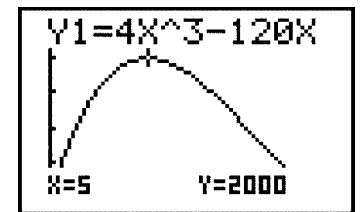

Summary

This exercise shows that the volume of the box depends on the size of the cut out squares. You can determine the best size for the cuts by observing where on the X-axis the maximum value of Y is reached.

Check the V and x range settings before performing the operation.

AR-3 Concrete Mix Design (Circle Graph)

Exercise 3

The materials produced by a concrete mix design are shown below.

Use a graphic scientific calculator to draw a graph of this mixture.

Mixture Table

Coarse Aggregate Maximum Size [mm]	Slump [cm]	Air Content [%]	Water/Cement Ratio W/C [%]	Fine Aggregate Ratio s/a [%]	Unit Weight [kg/m ³]						
					Water	Cement	Admixture	Fine Aggregate	Coarse Aggregate G		Admixture Agent
					W	C	F	S	mm 5 mm	mm 40 mm	[g/m ³]
25	7.5	5	50	41	183	311	0	761		1065	25

Explanation

Creating a graph of concrete material unit weights provides a visual overview of percentages of each material. The common way to do this is using a bar graph, like the one shown below.

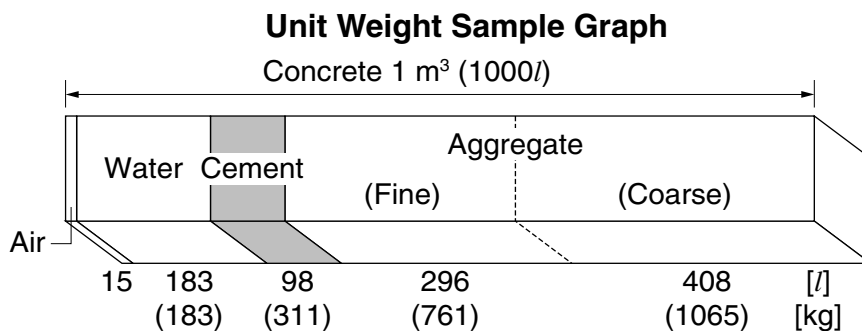

The following operation uses a graphic calculator to produce a circle graph of the above data.

Operation

• Expression Input

From the Main Menu, enter the STAT Mode.

After making sure the cursor is located in line 1 of List 1, input the following data.

- 15 [EXE]
- 183 [EXE]
- 98 [EXE]
- 296 [EXE]
- 408 [EXE]

	List 1	List 2
4	296	
5	408	
6		

GRAPH CALC SRT-A SRT-D

F1 (GRPH) **F2** (▶) **F4** (SET) **F5** (▼) **F3** (Pie) **QUIT**

```
StatGraph1
G-Type :Pie
Data   :List1
Display:%
-----
Scat  XY  Pie  Stck
```

F1 (GRPH) **F1** (GPH1)

This displays a graph like the one shown nearby.

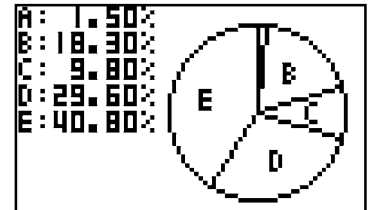

Summary

A circle graph provides a visual overview of percentages of each material in a concrete mix. For example, C indicates that 9.80% of the mixture is cement. If we say this value is about 10, we can say that the volume of water (B) is 1.8 times, the volume of fine aggregate or sand (D) is about 3 times, and the volume of coarse aggregate (E) is about 4 times that of cement.

This information can be used on a construction site by multiplying the number of buckets of cement by the values noted above.

Q-1 Material Quality Control (Histogram)

JIKKYO SHUPPAN CO., LTD.: SHIN KIKAI KOSAKU 2

Measurement of the diameters of 100 round rods that were to have been shaved to a diameter of 35 mm revealed variation ranging from 34.55 to 35.45. Measurements were divided into a number of ranges, which revealed the frequency distribution table shown below. This data was used to create a bar graph histogram showing the frequency of the measured values, combined with a distribution curve based on the median of each division.

Rod Diameter Measured Values									
	Measured Value								
1	34.6	34.68	34.82	34.91	34.96	35.06	35.22	35.32	35.36
2		34.71	34.76	34.87	35.02	35.08	35.18	35.32	35.35
3		34.66	34.75	34.85	35.03	35.08	35.21	35.34	
4		34.71	34.83	34.91	35.02	35.14	35.2	35.28	
5		34.65	34.78	34.86	35.04	35.11	35.15	35.34	
6		34.67	34.84	34.88	35.01	35.05	35.18	35.25	
7		34.67	34.75	34.85	35	35.07	35.15		
8			34.75	34.85	34.95	35.13	35.19		
9			34.75	34.89	35	35.1	35.21		
10			34.83	34.91	35.01	35.11	35.19		
11			34.79	34.87	35.02	35.08	35.2		
12				34.94	34.99	35.09	35.17		
13				34.94	34.97	35.05			
14				34.86	34.99	35.13			
15				34.89	35.02	35.05			
16				34.85	34.97	35.1			
17				34.86	34.98	35.1			
18					35.03	35.07			
19					34.98	35.09			
20					34.96	35.08			
21					35.04				
22					35				
23					34.97				
24					35.03				
Division Number	1	2	3	4	5	6	7	8	9
Diameter Range [mm]	34.55~34.65	34.65~34.75	34.75~34.85	34.85~34.95	34.95~35.05	35.05~35.15	35.15~35.25	35.25~35.35	35.35~35.45
Median	34.60	34.70	34.80	34.90	35.00	35.10	35.20	35.30	35.40
Frequency	1	7	11	17	24	20	12	6	2
									100

Frequency Distribution Table

Division Numbers	Diameter Range [mm]	Median [mm]	Frequency Count	Frequency
1	34.55~34.65	34.60	/	1
2	34.65~34.75	34.70	//// //	7
3	34.75~34.85	34.80	//// //// /	11
4	34.85~34.95	34.90	//// //// //// //	17
5	34.95~35.05	35.00	//// //// //// //// //// ////	24
6	35.05~35.15	35.10	//// //// //// ////	20
7	35.15~35.25	35.20	//// //// //	12
8	35.25~35.35	35.30	//// /	6
9	35.35~35.45	35.40	//	2
	Total			100

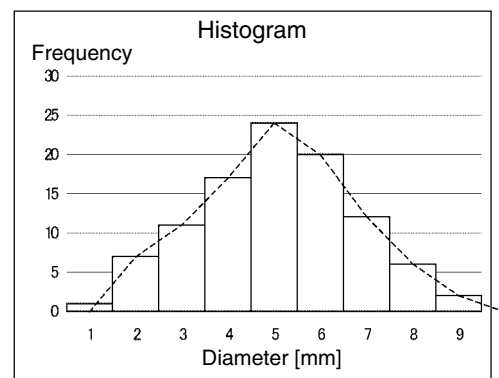

Histogram

Now we will use our graphic calculators to draw a distribution curve based on the measured diameters of the 100 rods.

We will use the program mode and use random numbers as the measured data. See “Program Creation” on the next page for information about the program.

Note

Calculator key operations and displays are indicated inside the broken line box.

- ◀ ▶ ◂ ▸ indicate cursor key operations.
- ▶ indicates the far right function key (next to **F4**).

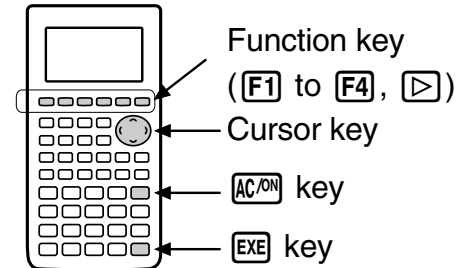

Operation

MENU 6

◂ **EXE**

(*Select the program "HISTDATA.")

MENU 6

(*Select the program "HISTLINE.")

◂ **EXE**

MENU 2

F1 (GRPH) ▶ **F4** (SET) **F1** (GPH1)

◂ ▶ **F1** (Hist) ◂ **F1** (List1)

◂ **F1** (1)

▲ ▲ ▲ **F2** (GPH2) ◂ **F2** (xy)

◂ **F2** (List2) ◂ **F3** (List3)

◂ **F1** (1) ◂ **F3** (•) **QUIT**

SHIFT **MENU** (SET UP) **F2** (Man) **QUIT**

F1 (GRPH) **F1** (GPH1) 34.55 **EXE**

0.1 **EXE** **F4** (DRAW)

QUIT **F1** (GRPH) **F2** (GPH2)

QUIT

: From the Main Menu, enter the PRGM Mode.

: Run the program "HISTDATA".
: HISTDATA inputs the measured values into List 1.

: From the Main Menu, enter the PRGM Mode.
: HISTLINE inputs each median and frequency into List 2 and List 3.
: Run the program "HISTLINE".

: From the Main Menu, enter the STAT Mode.

: Graph 1 is specified as the histogram of List 1.

: Graph 2 is the *xy* graph of List 2 and List 3.

: Manually configure graph mode settings.

: Draw the histogram.

: Draw the broken line graph.

HISTDATA Program Creation

MENU 6

F3 (NEW)

F \rightarrow D (H) **C** (I) **X** (S) **\div** (T) **sin** (D) **X,T** (A)

\div (T) **X,T** (A) **EXE**

SHIFT **VARS** (PRGM) **\triangleright** **F3** (CLR) **F2** (Grph)

EXE

F3 (List) **EXE**

SHIFT **F3** (V-WIN) **F1** (V-Win) 34.5 **\blacktriangleright** 35.5

\blacktriangleright 0.1 **\blacktriangleright** **(\leftarrow)** 8 **\blacktriangleright** 30 **\blacktriangleright** 5 **EXE**

OPTN **F1** (LIST) **\triangleright** **F1** (Seq) **C** **X,T** (X)

\blacktriangleright **X,T** (X) **\blacktriangleright** 1 **\blacktriangleright** 100 **\blacktriangleright** 1 **)** **\rightarrow** **\triangleright**

\triangleright **F1** (List) 1 **EXE**

34.55 **+** **OPTN** **\triangleright** **F1** (NUM) **F2** (Int)

C **OPTN** **F4** (PROB) **F4** (Ran#) **X** 10 **)**

\div 100 **\rightarrow** **OPTN** **F1** (LIST) **F1** (List)

1 **SHIFT** **+** (I) 1 **SHIFT** **-** (J) **EXE**

SHIFT **VARS** (PRGM) **F1** (COM) **\triangleright** **F1** (For)

2 **\rightarrow** **ALPHA** **C** (I) **F2** (To) 8 **EXE**

: From the Main Menu, enter the PRGM Mode.

: Select NEW PROGRAM.

: Specify "HISTDATA" as the program name.

: Reset the statistical graph.

: Reset the LIST data.

: Specify the display range of the graph.

: Save the data range to LIST (100 items).

: Input a random value between 34.55 to 34.65 into List 1 [1] (data item 1).

: Repeat the lines between the For statement and Next statement for variable I values from 2 to 8.

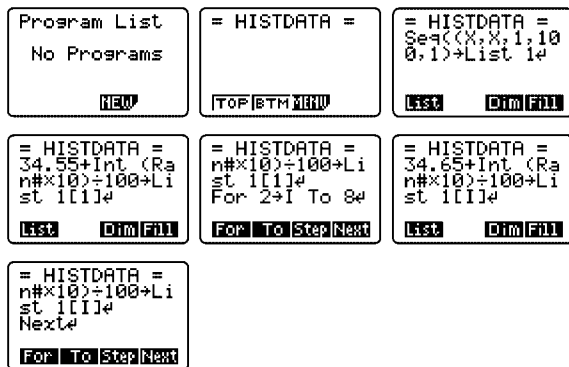

HISTDATA Program Creation (continued)

34.65 \oplus OPTN \triangleright F1 (NUM) F2 (Int) C OPTN
 F4 (PROB) F4 (Ran#) $\times 10$ C $\div 100$ C
 OPTN F1 (LIST) F1 (List)1 SHIFT \oplus (I) ALPHA C (I)
 SHIFT C (I) EXE
 SHIFT VARS (PRGM) F1 (COM) \triangleright F4 (Next)
 EXE
 F1 (For) 9 C ALPHA C (I) F2 (To) 19 EXE

: Input random values between 34.65 to 34.75 into the lines from List 1 [2] to List 1 [8].

: Input the Next statement.

: Repeat the lines between the For statement and Next statement for variable I values from 9 to 19.

34.75 \oplus OPTN \triangleright F1 (NUM) F2 (Int) C OPTN
 F4 (PROB) F4 (Ran#) $\times 10$ C $\div 100$ C
 OPTN F1 (LIST) F1 (List)1 SHIFT \oplus (I) ALPHA C (I)
 SHIFT C (I) EXE
 SHIFT VARS (PRGM) F1 (COM) \triangleright F4 (Next) EXE

: Input random values between 34.75 to 34.85 into the lines from List 1 [9] to List 1 [19].

: Input the Next statement.

<pre>= HISTDATA = 34.65+Int (Ra n#*10)+100+Li st 1111e List Dim Fill</pre>	<pre>= HISTDATA = n#*10)+100+Li st 1111e Nexte For To Step Next</pre>	<pre>= HISTDATA = st 1111e For 9+I To 19 e TOP/BTM MENU</pre>	<pre>= HISTDATA = 34.75+Int (Ra n#*10)+100+Li st 1111e List Dim Fill</pre>
<pre>= HISTDATA = Nexte For 20+I To 3 6e For To Step Next</pre>	<pre>= HISTDATA = 34.85+Int (Ra n#*10)+100+Li st 1111e TOP/BTM MENU</pre>	<pre>= HISTDATA = Nexte For 37+I To 6 0e For To Step Next</pre>	<pre>= HISTDATA = 34.95+Int (Ra n#*10)+100+Li st 1111e List Dim Fill</pre>
<pre>= HISTDATA = Nexte For 61+I To 8 0e For To Step Next</pre>	<pre>= HISTDATA = 35.05+Int (Ra n#*10)+100+Li st 1111e List Dim Fill</pre>	<pre>= HISTDATA = Nexte For 81+I To 9 2e For To Step Next</pre>	<pre>= HISTDATA = 35.15+Int (Ra n#*10)+100+Li st 1111e List Dim Fill</pre>
<pre>= HISTDATA = Nexte For 93+I To 9 8e For To Step Next</pre>	<pre>= HISTDATA = 35.25+Int (Ra n#*10)+100+Li st 1111e List Dim Fill</pre>	<pre>= HISTDATA = Nexte For 99+I To 1 00e For To Step Next</pre>	<pre>= HISTDATA = 35.35+Int (Ra n#*10)+100+Li st 1111e List Dim Fill</pre>
<pre>= HISTDATA = n#*10)+100+Li st 1111e Nexte For To Step Next</pre>			

: Input the program referring to the screens to the left.

: Program the following lines.

- From 34.85 to 34.95 → List 1 [20] to [36]
- From 34.95 to 35.05 → List 1 [37] to [60]
- From 35.05 to 35.15 → List 1 [61] to [80]
- From 35.15 to 35.25 → List 1 [81] to [92]
- From 35.25 to 35.35 → List 1 [93] to [98]
- From 35.35 to 35.45 → List 1 [99] to [100]

OPTN F1 (LIST) F1 (List)1 EXE
 QUIT QUIT

```
Program List  
HISTDATA  
EXE EDIT NEW
```

: Displays the contents of List 1 and quits.

■ HISTLINE Program Creation

Histogram: Broken line graph

The program creates a broken line graph by connecting the median values in each histogram division with lines.

The broken line graph is based on the median value (horizontal axis) of each division in the graph and the frequency of the data (vertical axis).

<p>MENU 6</p> <p>F3 (NEW)</p> <p>F→D (H) ((I) X (S) ÷ (T) → (L) ((I)</p> <p>8 (N) cos (E) EXE</p> <p>OPTN F1 (LIST) ▶ F1 (Seq) (X,T (X) ,</p> <p>X,T (X) , 1 , 9 , 1) → ▶ ▶ F1 (List)</p> <p>2 EXE</p> <p>SHIFT VARS (PRGM) F1 (COM) ▶ F1 (For)</p> <p>1 → ALPHA ((I) F2 (To) 9 EXE</p> <p>34.5 + ALPHA ((I) ÷ 10 → OPTN F1 (LIST)</p> <p>F1 (List) 2 SHIFT + (I) ALPHA ((I) SHIFT - (I)</p> <p>EXE</p> <p>SHIFT VARS (PRGM) F1 (COM) ▶ F4 (Next) EXE</p> <p>SHIFT X (I) 1 , 7 , 11 , 17 ,</p> <p>24 , 20 , 12 , 6 , 2</p> <p>SHIFT ÷ (I) → OPTN F1 (LIST) F1 (List) 3 EXE</p> <p>OPTN F1 (LIST) F1 (List) 3 EXE QUIT QUIT</p>	<p>Program List = HISTLINE =</p> <p>No Programs</p> <p>NEW TOP/BTM MENU</p>	<p>: From the Main Menu, enter the PRGM Mode.</p> <p>: Select NEW PROGRAM.</p> <p>: Specify "HISTLINE" as the program name.</p> <p>: Store the nine data ranges in List 2.</p> <p>: In List 2, input 34.6, 34.7, ... 35.4.</p> <p>: Input the frequency data into List 3.</p> <p>: {1,7,11,17,24,20,12,6,2} → List 3</p> <p>: Displays the contents of List 3 and quits.</p>
---	---	--

Q-2 Component Quality Variation Control (\bar{X} -R Control Chart)

JIKKYO SHUPPAN CO., LTD.: SHIN KIKAI KOSAKU 2

The \bar{X} -R control chart is widely used to control variations in dimensions, quality, strength, and other qualities. \bar{X} is the mean value and R is the range, which is the difference between the maximum and minimum values of a group of data. This data expresses variance instead of standard deviation.

The data sheet below was created by selecting five items from each of 25 lots. The diameter of each item was measured and recorded in the data sheet, which was then used to create the \bar{X} -R control chart.

\bar{X} -R Control Chart Data Sheet (Example)

Group Number	Measured Values [mm]					Total Σx	Mean \bar{X}	Range R
	X 1	X 2	X 3	X 4	X 5			
1	75.98	75.90	75.93	75.91	76.01	379.73	75.946	0.11
2	75.88	75.86	75.93	75.91	75.89	379.47	75.894	0.07
3	75.96	75.90	75.94	75.98	75.87	379.65	75.930	0.11
4	75.93	75.91	75.88	75.93	75.91	379.56	75.912	0.05
5	75.93	75.94	75.86	76.00	75.99	379.72	75.944	0.14
6	75.97	75.91	75.90	75.95	75.92	379.65	75.930	0.07
7	75.88	75.91	75.91	75.92	75.88	379.50	75.900	0.04
8	75.96	75.85	75.93	75.92	75.91	379.57	75.914	0.11
9	75.93	75.90	75.85	75.94	75.91	379.53	75.906	0.09
10	75.90	75.92	75.89	75.94	75.91	379.56	75.912	0.05
11	75.94	75.86	75.88	75.92	75.94	379.54	75.908	0.08
12	75.87	75.96	75.93	75.84	75.92	379.52	75.904	0.12
13	75.87	75.94	75.88	75.92	75.91	379.52	75.904	0.07
14	75.95	75.96	75.92	75.90	75.96	379.69	75.938	0.06
15	75.90	76.02	75.93	75.92	75.93	379.70	75.940	0.12
16	75.94	75.90	75.93	75.94	75.92	379.63	75.926	0.04
17	75.89	75.94	75.88	75.92	75.96	379.59	75.918	0.08
18	75.96	75.94	75.95	75.91	75.92	379.68	75.936	0.05
19	75.92	75.89	75.97	75.90	75.92	379.60	75.920	0.08
20	75.90	75.95	75.87	75.92	75.90	379.54	75.908	0.08
21	75.89	75.97	75.90	75.91	75.91	379.58	75.916	0.08
22	75.98	75.97	75.92	75.89	75.92	379.68	75.936	0.09
23	75.86	75.87	75.93	75.91	75.98	379.55	75.910	0.12
24	75.95	75.91	75.93	75.89	75.92	379.60	75.920	0.06
25	75.95	75.83	75.89	75.91	75.95	379.53	75.906	0.12
						Total	1897.978	2.09
							$\bar{X} = 75.919$	R = 0.084

Use the values in the data sheet to determine the mean (\bar{X}) and range (\bar{R}) for each of the data groups. Next, use the \bar{X} control chart coefficient table below to determine the A_2 , D_3 , and D_4 coefficients in accordance with the number of measured values in each group (sample size n). Using these coefficients, determine the upper control limit (UCL) and lower control limit (LCL) for the mean value (\bar{X}) and range (R) as shown below, and create the control chart.

\bar{X} Control Chart Coefficient Table

Sample Size n	A_2	D_3	D_4
2	1.88	— — —	3.27
3	1.02	— — —	2.57
4	0.73	— — —	2.28
5	0.58	— — —	2.11
6	0.48	— — —	2.00
7	0.42	0.08	1.92
8	0.37	0.14	1.86
9	0.34	0.18	1.82
10	0.31	0.22	1.78

\bar{X} Control Chart $UCL = \bar{\bar{X}} + A_2 \cdot \bar{R}$, $LCL = \bar{\bar{X}} - A_2 \cdot \bar{R}$

* $\bar{\bar{X}}$ is the mean of the mean values (\bar{X}).

R Control Chart $UCL = D_4 \cdot \bar{R}$, $LCL = D_3 \cdot \bar{R}$

[Calculation]

$$\bar{\bar{X}} = \frac{1897.978}{25} = 75.919, \quad \bar{R} = \frac{2.09}{25} = 0.084$$

$A_2 = 0.58$, $D_4 = 2.11$ (For sample size $n = 5$).

\bar{X} Control Chart $UCL = 75.919 + 0.58 \times 0.084 = 75.967$

$LCL = 75.919 - 0.58 \times 0.084 = 75.870$

R Control Chart $UCL = 2.11 \times 0.084 = 0.177$

Using the STAT function of the graphic calculator, input the lot numbers and measured values into lists, calculate the mean and range, and then graph the results using the statistical graph function.

The actual operation of the calculator is shown below.

Note

Calculator key operations and displays are indicated inside the broken line box.

- ◀ ▶ ◂ ▸ indicate cursor key operations.
- ▶ indicates the far right function key (next to **F4**).

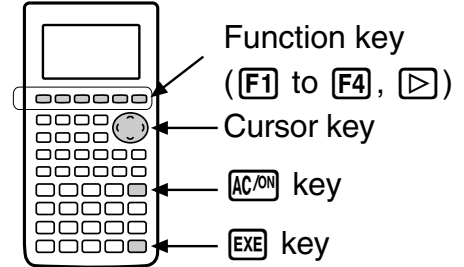

Operation

MENU 2			
75.98 EXE 75.88 EXE ...			: From the Main Menu, enter the STAT Mode.
▶			: Confirm that the cursor is located in the first line of List 1.
75.90 EXE 75.86 EXE ...			: Input the 25 values for the x1 measurements into List 1.
▶			: Move the cursor to the first line of List 2.
75.93 EXE 75.93 EXE ...			: Input the 25 values for the x2 measurements into List 2.
▶			: Move the cursor to the first line of List 3.
75.91 EXE 75.91 EXE ...			: Input the 25 values for the x3 measurements into List 3.
▶			: Move the cursor to the first line of List 4.
76.01 EXE 75.95 EXE ...			: Input the 25 values for the x4 measurements into List 4.
			: Move the cursor to the first line of List 5.
			: Input the 25 values for the x5 measurements into List 5.

* Instead of the manual input procedure used above, you can also use the program function to input data. This comes in handy when you have a large number of values to input. See “XRDATA Program Creation” for information about using a program.

MENU 6	
◂ EXE	
(*Select the program “XRDATA.”)	

- : From the Main Menu, enter the PRGM Mode.
- : Run the program named “XRDATA”.

MENU 2

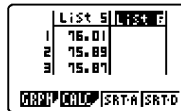

- : From the Main Menu, enter the STAT Mode.
- : Move the cursor to the first line of List 6.
- : Select the title of List 6.

(**OPTN** **F1** (LIST) **F1** (List) 1 **+** **F2** (List) 2 **+** **F3** (List) 3 **+** **F1** (List) 4 **+** **F1** (List) 5 **)** **÷** 5 **EXE**

- : Calculate mean values for entry into List 6.

MENU 1

OPTN **F1** (LIST) **F1** (List) 6 **EXE**



- : From the Main Menu, enter the RUN Mode.
- : Save the mean values (List 6) in List Ans memory.

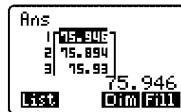

MENU 2

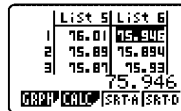

- : From the Main Menu, enter the STAT Mode.
- : Move the cursor to the first line of List 6.

76.01 **−** 75.90 **EXE**

75.93 **−** 75.86 **EXE**

••••

75.95 **−** 75.83 **EXE**

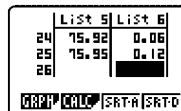

- : Input the range of each group (maximum value minus minimum value).

MENU 1

OPTN **F1** (LIST) **F1** (List)

SHIFT **(←)** (Ans) **→** **F1** (List) 5 **EXE**

OPTN **F1** (LIST) **▷** **F1** (Seq)

X,T (X) **,** **X,T** (X) **,** 1 **,** 25 **,**

1 **)**

→ **▷** **▷** **F1** (List) 1 **EXE**

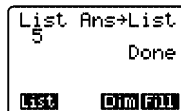

- : From the Main Menu, enter the RUN Mode.
- : Input the mean values (List Ans) into List 5.

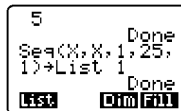

- : Enter the group numbers in List 1. Use Seq (sequence) function.
- : Entry Syntax = variable, expression, start item, end item, interval

: Execute.

MENU 1

OPTN **F1** (LIST) **▶▶** **F2** (Sum) **▶**

F1 (List) **5** **→** **ALPHA** **X,T** (A) 

EXE

▶▶ **F2** (Sum) **▶**

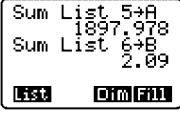
F1 (List) **6** **→** **ALPHA** **log** (B) 

EXE

ALPHA **X,T** (A) **÷** **25** **→** **ALPHA** **+** (X) **EXE**

ALPHA **log** (B) **÷** **25** **→** **ALPHA** **6** (R) **EXE**

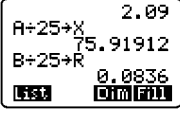

ALPHA **+** (X) **+** **0.58** **✕** **ALPHA** **6** (R) **→**

ALPHA **1** (U) **EXE**



ALPHA **+** (X) **-** **0.58** **✕** **ALPHA** **6** (R) **→**

ALPHA **→** (L) **EXE**

F4 (Fill) **ALPHA** **+** (X) **,** **F1** (List) **2** **)** **EXE**

F4 (Fill) **ALPHA** **1** (U) **,** **F1** (List) **3** **)** **EXE**

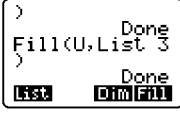
F4 (Fill) **ALPHA** **→** (L) **,** **F1** (List) **4** **)** **EXE**

: From the Main Menu, enter the RUN Mode.

: Assign the mean value (List 5) total to Memory A.

: Assign the range value (List 6) total to Memory B.

: Calculate the mean of the mean values and assign it to Memory X.

: Calculate the mean of the range values and assign it to Memory R.

: Calculate the UCL and assign it to Memory U.

: Calculate the LCL and assign it to Memory L.

: Input the mean of the mean values into List 2.

: Input the UCL value into List 3.

: Input the LCL value into List 4.

MENU 2

F1 (GRPH) **F4** (SET)

F1 (GPH1)

F2 (xy)

F1 (List1) **F1** (List5)

F1 (□)

F2 (GPH2)

F2 (xy)

F1 (List1) **F2** (List2)

F3 (•)

F3 (GPH3)

F1 (Scat)

F1 (List1) **F3** (List3)









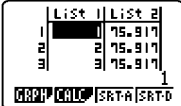

F3 (•)

SHIFT **MENU** **F1** (Auto) **QUIT**

QUIT **F1** (GRPH) **F1** (SEL) **F1** (On)

F1 (On) **F1** (On)

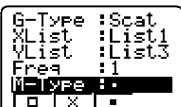
F4 (DRAW)

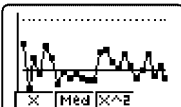
: From the Main Menu, enter the STAT Mode.

: Display the graph setting screen.

: Select StatGraph1.

: Select xy Line.

: Specify List 1 (group numbers) for the horizontal axis.
Specify List 5 (data) for the vertical axis.

: Specify □ as the mark type.

: Select StatGraph2.

: Select xy Line.

: Specify List 1 (group numbers) for the horizontal axis.
Specify List 2 (mean values) for the vertical axis.

: Specify • as the mark type.

: Select StatGraph3.

: Select Scatter plot.

: Specify List 1 (group numbers) for the horizontal axis.
Specify List 3 (UCL) for the vertical axis.

: Specify • as the mark type.

: Specify AUTO as the graph mode.

: Turn on graphing for Graph 1, Graph 2, and Graph 3.

: Draw the graphs.

This is a control chart for a stable situation.

Try drawing Graph 3 using the LCL (List 4) for YList.

As an exercise, change some of the data and try drawing an unstable control chart.

■ XRDATA Program Creation

Control Chart Data

MENU 6

F3 (NEW)

+ (X) **6** (R) **sin** (D) **X,T** (A)

÷ (T) **X,T** (A) **EXE**

SHIFT **X** ({} 75.98 **↵** 75.88 **↵** ...

... **↵** 75.95 **SHIFT** **÷** ({})

→ **OPTN** **F1** (LIST) **F1** (List) 1 **EXE**

SHIFT **X** ({} 75.90 **↵** 75.86 **↵** ...

... **↵** 75.83 **SHIFT** **÷** ({})

→ **F1** (LIST) **F1** (List) 2 **EXE**

SHIFT **X** ({} 75.93 **↵** 75.93 **↵** ...

... **↵** 75.89 **SHIFT** **÷** ({})

→ **F1** (LIST) **F1** (List) 3 **EXE**

SHIFT **X** ({} 75.91 **↵** 75.91 **↵** ...

... **↵** 75.91 **SHIFT** **÷** ({})

→ **F1** (LIST) **F1** (List) 4 **EXE**

SHIFT **X** ({} 76.01 **↵** 75.89 **↵** ...

... **↵** 75.95 **SHIFT** **÷** ({})

→ **OPTN** **F1** (LIST) **F1** (List) 5 **EXE**

QUIT **F1** (EXE)

Program List
No Programs
NEW

: From the Main Menu, enter the PRGM Mode.

: Select NEW PROGRAM.

= XRDATA =
TOP **BTM** **MENU**

: Input XRDATA as the program name.

: Input formula for List 1 data.

: Input formula for List 2 data.

: Input formula for List 3 data.

: Input formula for List 4 data.

: Input formula for List 5 data.

= XRDATA =
.90,75.91,75.
92,75.98,75.9
2,75.95)→List
5
TOP **BTM** **MENU**

Program List
XRDATA
EXE **EDIT** **NEW**

Done

: Execute the program.

Z-1 Using a Graphic Calculator (Displaying Calculation Results)

- (1) Fixed Point (Specifying the Number of Decimal Places)
Displaying results up to two decimal places.

SHIFT **MENU** (SET UP) **▼** **▼** **▼** **F1** (Fix) **F3** (2) **QUIT**

```
F-Type :Y=  
D-Type :Conct  
Angle :Deg  
Display:Fix2  
Simplify:Auto  
Fix Sci Norm
```

- (2) Floating Point (Specifying the Number of Significant Digits)
Displaying results up to three significant digits.

SHIFT **MENU** (SET UP) **▼** **▼** **▼** **F2** (Sci) **F4** (3) **QUIT**

```
F-Type :Y=  
D-Type :Conct  
Angle :Deg  
Display:Sci3  
Simplify:Auto  
Fix Sci Norm
```

- (3) Canceling the Number of Decimal Place and Number of Significant Digit Settings

SHIFT **MENU** (SET UP) **▼** **▼** **▼** **F3** (Norm) **QUIT**

```
F-Type :Y=  
D-Type :Conct  
Angle :Deg  
Display:Fix2  
Simplify:Auto  
Fix Sci Norm
```

Z-2 Using a Graphic Calculator (Inputting Statistical Data)

Operation

Table Input

From the Main Menu, enter the STAT Mode.

After confirming the cursor is in line 1 of List 1, input the voltage values.

(0 **EXE** 0.2 **EXE** 0.4 **EXE**, etc.)

After confirming the cursor is in line 1 of List 2, input the current values.

(0 **EXE** 0.002 **EXE** 0.004 **EXE**, etc.)

	List 1	List 2
1	0	0
2	0.2	2E-3
3	0.4	4E-3

GRPH CALC SRT-A SRT-D

Graph Settings

Press **F1** (GRPH) **▶** **F4** (SET) to check the graph settings. Use **▲** and **▼** to move the cursor around the display and use keys **F1** through **▶** to change the settings so they are like the ones shown on the screen nearby.

StatGraph1	
G-Type	:Scat
XList	:List1
YList	:List2
Freq	:1
GP1	GP2 GP3

Graphing

Press **QUIT** **F1** (GRPH) **F1** (GPH1) to display the graph (scatter diagram).



■ Data Editing

- To change data, move the cursor to the data you want to change and over write it with the correct data.
- To insert data, move the cursor to the location of the insert, and then press **▶** **F3** (INS).
- To delete data, move the cursor to the data you want to delete, and then press **▶** **F1** (DEL).

* To return from the graph screen to the data input screen, press **QUIT**.

Z-3 Using a Graphic Calculator (Determining the Slope of a Line)

Calculation of the slope and other information from the obtained data is performed using linear regression. Though the actual calculation is quite complex and difficult to perform, the graphic calculator performs linear regression in an instant and provides the slope and y-intercept.

Graphing

Press **QUIT** **F1** (GRPH) **F1** (GPH1) to display the graph (scatter diagram).

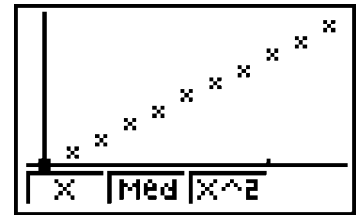

Linear Regression

Pressing **F1** (X) **F4** (DRAW) performs linear regression and overlays it onto the scatter diagram as shown on the screen nearby. Pressing **F1** displays the slope, which is the value indicated for "a =".



```
LinearReg
a= 1.015-02
b=-3.181-05
r= 0.99998
y=ax+b
COPY DRAW
```

Z-4 Creating Text Materials

Program-LINK software (FA-123) can be used to connect the fx-7400G PLUS graphic calculator to a computer and transfer screen shots. You can also exchange data and programs with a computer. The following is an example of how to use the screen shot transfer function to create text materials for the graphic calculator.

(1) Required Software and Cable

- ① Install the FA-123 software. FA-123 includes both Windows and Macintosh versions of the software, a special cable, and an adapter. The FA-123 software also can be downloaded from the CASIO Website. Use the special cable that comes with FA-123 to connect your graphic calculator to your computer.
- ② Use a word processor application to create the text materials.
- ③ Use a graphic application to edit the images.

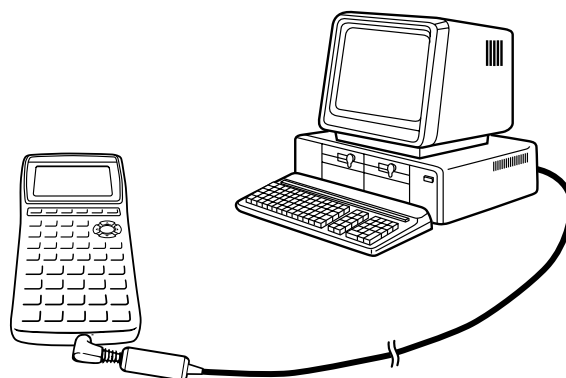

Figure 1 Graphic Calculator and Computer Connection

(2) Screen Capture

Start up the LINK software (Figure 2) and execute Link-Screen Capture. After the software goes into standby for screen image transfer from the graphic calculator, press **[F-D]** on the graphic calculator to transfer the screen image.

To execute SCREEN CAPTURE, perform the following operation from the MENU screen on the calculator.

Select 7:LINK.

[F4] (IMAGE)

[F2] (On)

[MENU]

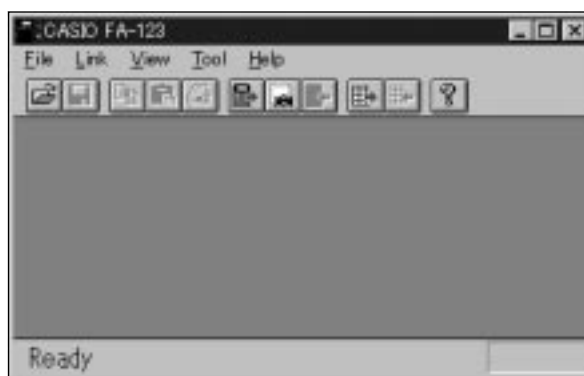

Figure 2 Link Soft Startup Screen

This turns on the calculator's image transfer mode as shown in Figure 3.



Figure 3 Graphic Calculator Setup

Figure 4 shows the computer screen after capture of a graph screen from the graph calculator. This image can be saved directly to a file, or you can copy it and paste it into another application.



Figure 4 Screen Capture

(3) Pasting Images

Use the following procedure to paste an image into a word processor or other application you are using to create materials.

- ① Display the screen you want on the graphic calculator.
- ② Use the LINK software to execute Link-Screen Capture.
- ③ On the graphic calculator, press **F+D**.
- ④ Use File Save to save the image for later use. Or you can perform the next two steps to use it right away.
- ⑤ Use the LINK software's Edit-Copy command to copy the image to the clipboard (Figure 5).
- ⑥ In the application where you want to paste the image, specify the location where you want to paste the image and then execute the Paste command

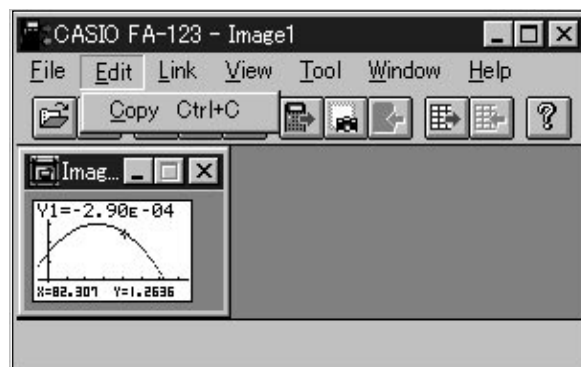

Figure 5 Copying an Image to the Clipboard

The menu shown in Figure 6 can also be pasted into a graphic application and edited. Saved images can then be used inside of text.

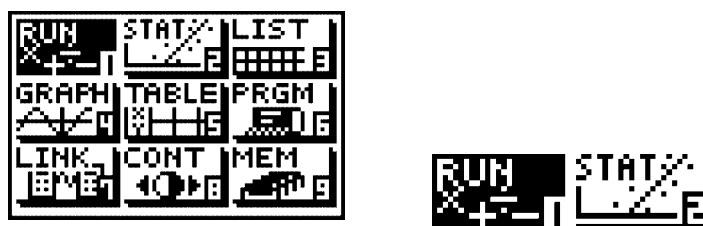

Figure 6 Cutting an Image from the Menu Screen

Supervisor

Professor Shozo Yamashita

Faculty of Engineering Takushoku University

Authors (Alphabetically)

Takashi Fukazawa

University of Tsukuba Senior High School at Sakado

Hiroaki Hashimoto

Setagayaizumi High School (Tokyo)

Yuji Kudo

University of Tsukuba Senior High School at Sakado

Hideyo Makishita

University of Tsukuba Junior and Senior High School at Komaba

Akihiro Shimizu

Tanashi Technical High School (Tokyo)

Mitsugu Tatara

Nakano Technical High School (Tokyo)

Special thanks to:

Masanori Oogiyonagi

Masuda Junior High School

MEMO

MEMO

MEMO